

esti&esta<sup>®</sup>

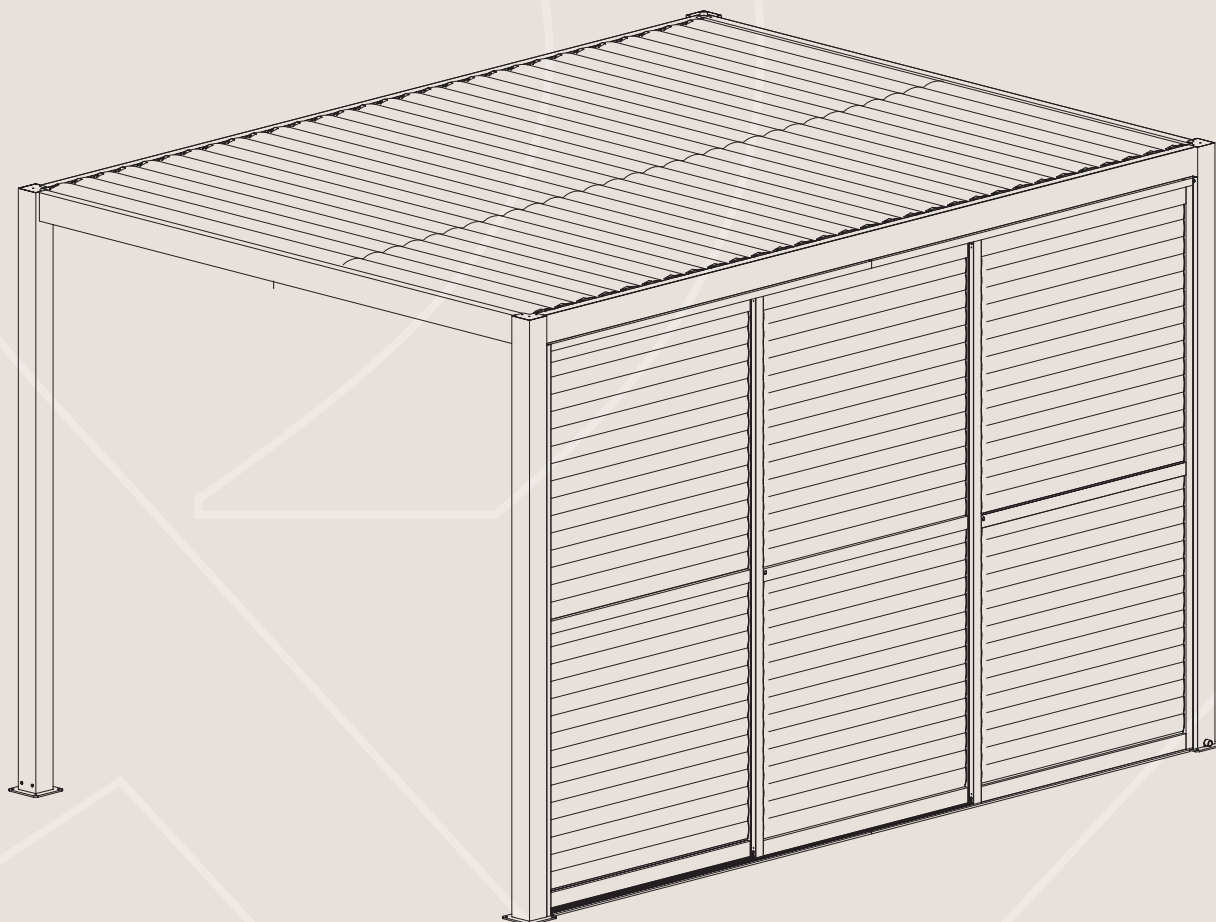

# LUXE

Drzwi przesuwne żaluzjowe (3m / 4m)

Instrukcja montażu

Mobile door 9631 (3m / 4m)  
Assembly instructions

# Zalecane narzędzia / What you may need?

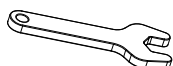
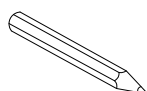
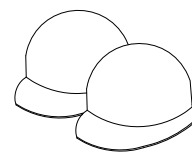
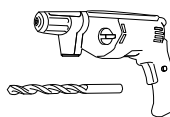
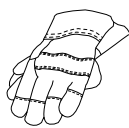
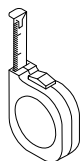
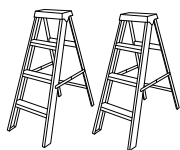

lub  
or

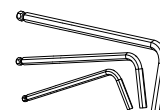
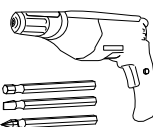

1. Drabina
2. Miarka
3. Młotek gumowy
4. Rękawice ochronne
5. Wiertarka (z wiertłem 3.3mm oraz 8 mm)
6. Kask ochronny
7. Poziomica
8. Marker
9. Klucz
10. Śrubokręt lub wkrętarka
11. Klucz imbusowy (5 mm)

1. Ladder
2. Tapeline
3. Mallet
4. Glove
5. Electric screw driver (3.3 mm and 8 mm)
6. Safety hat
7. Level
8. Marker Pen
9. Adjustable wrench
10. Screwdriver or electric screwdriver
11. Allen key (5 mm)

Zalecamy udział dwóch (lub więcej) osób do montażu.

Two or more people for assembly.



## Czyszczenie i konserwacja

/ Care and cleaning

Do czyszczenia nie używać materiałów ściernych i agresywnych środków chemicznych.

Never use abrasive materials, solvents, bleach, acids or other chemically aggressive agents for cleaning.

Należy czyścić gąbką (lub miękką szmatką) z ciepłą wodą, w razie konieczności z dodatkiem łagodnego detergentu.

Elements should be cleaned with a sponge with warm water, if necessary with a mild detergent.

Nie używać czyszczenia wysokociśnieniowego, które może powodować uszkodzenia konstrukcji.

Do not use high pressure cleaning, which will wash out the material and damage the surface of the structure.







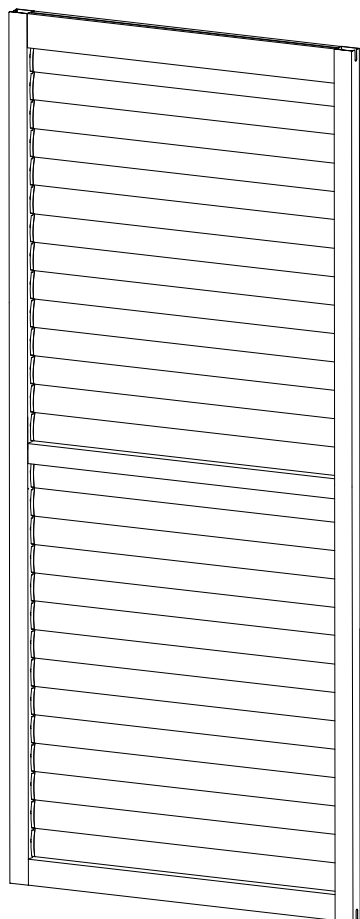



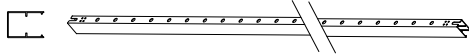

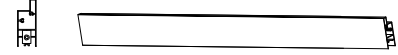
Należy okresowo sprawdzać i upewniać się, że wszystkie śruby są odpowiednio dokręcone.

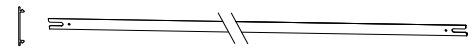
Periodically check and ensure that all the screws are properly tightened.

# Lista części / List of parts



x3

A			x2
B			x1
C			x1
D			x1
E			218cm (x28) 238 cm (x30)
F			x2
G			x2
I	1		218cm (x56) 238 cm (x60)
II	2		x16 ST4.2*20
III	3		x4
	4		x4
	5		x4
	6		x4 ST4.2*10
IV	7		218cm (x28) 238 cm (x30) ST2.2*14

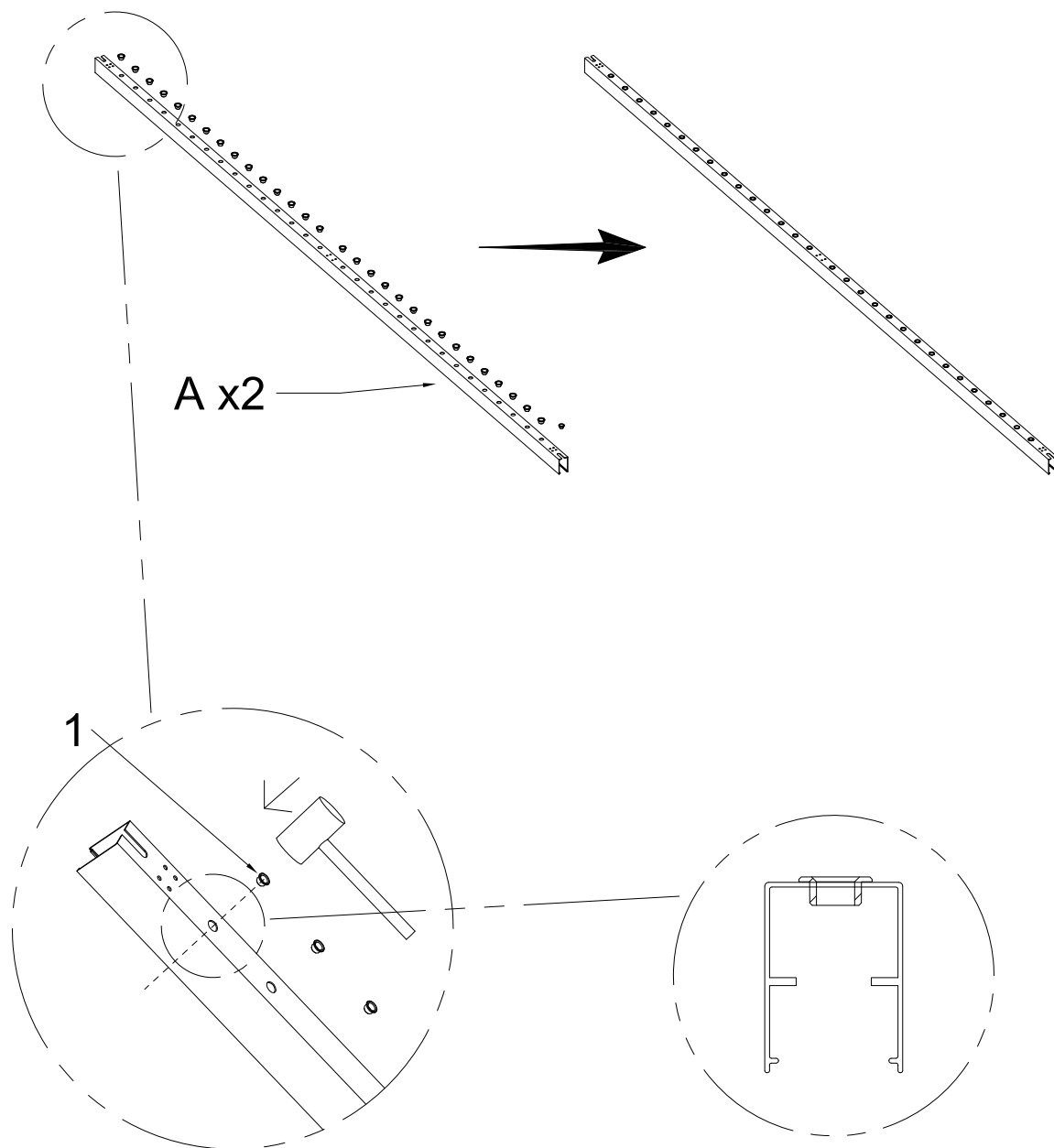

# 1. Montaż ramy.

# 1. Assemble door frame.



Wskazówka: Podczas monażu tulejek, zwróć uwagę, aby przylegały płasko do ramy. Nie mogą być zdeformowane lub podwinięte.

Tips: When installing the sleeve, it must be attached to the frame. Make sure it is flat and not wrapped.

A	 	x2	1		x56 / x60
---	---	----	---	---	-----------

## 2. Montaż środkowej belki.

## 2. Combination door frame and middle beam

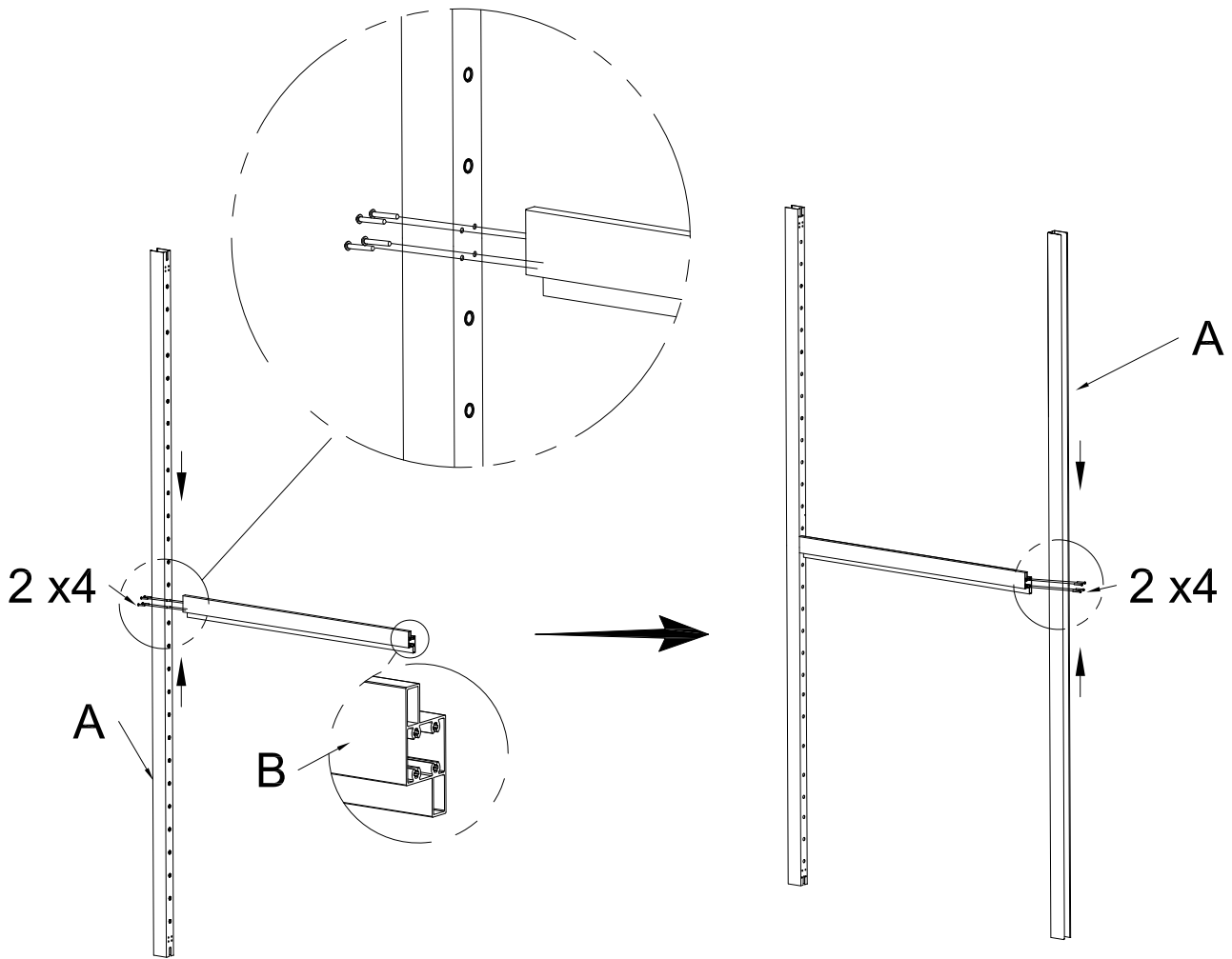



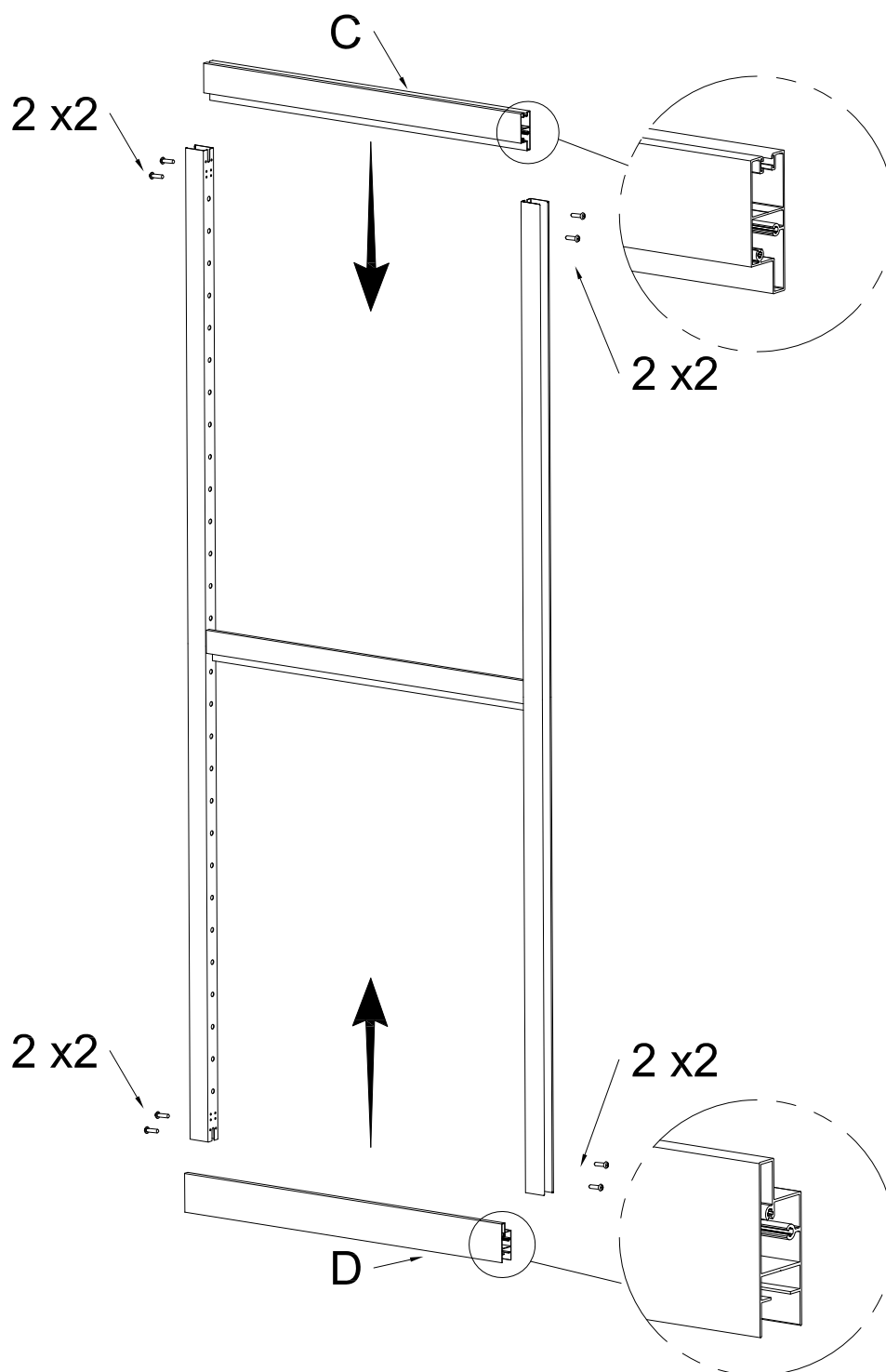

<b>B</b>			x1	<b>2</b>		x8	ST4.2*20
----------	---	---	----	----------	---	----	----------

3. Montaż górnej i dolnej belki.

3. Install the upper and lower beams.

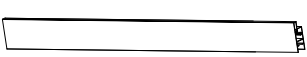

C			x1
D			x1
2		ST4.2*20	x8

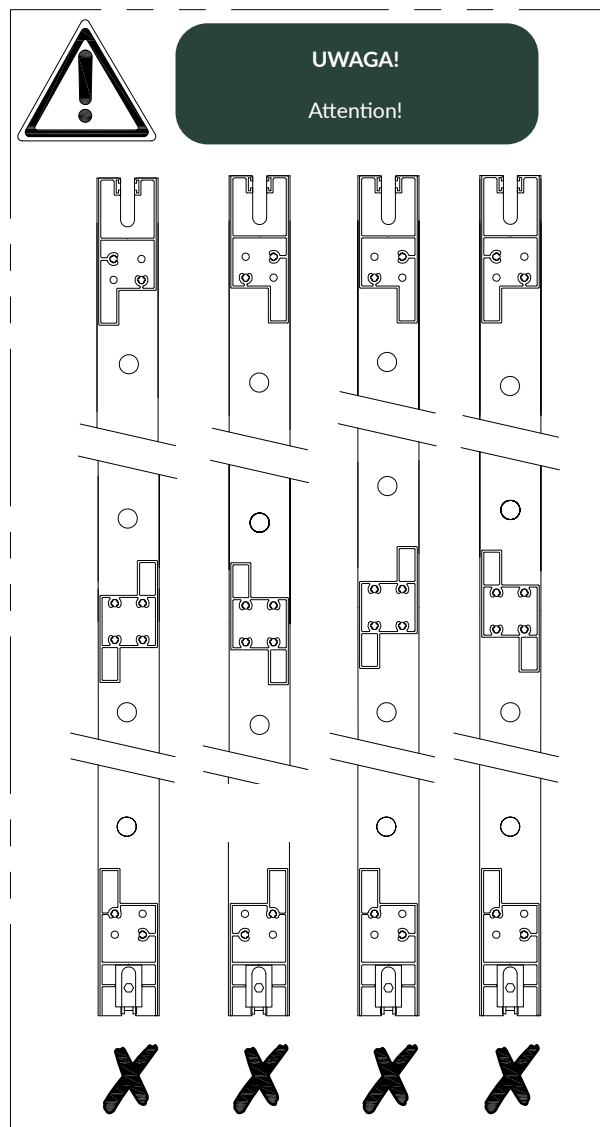
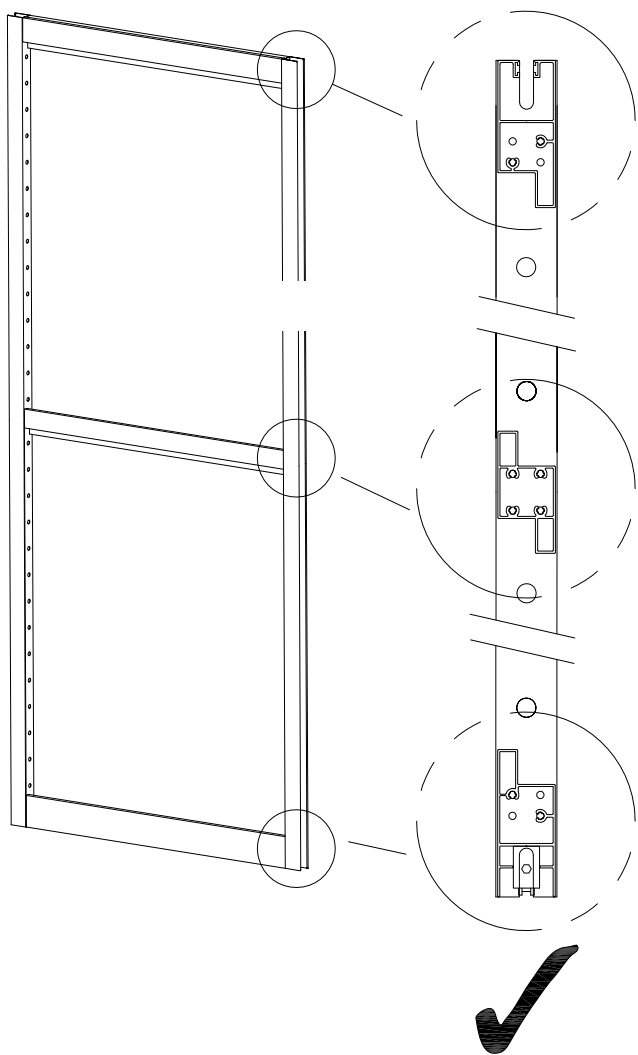

#### 4. Montaż żaluzji.



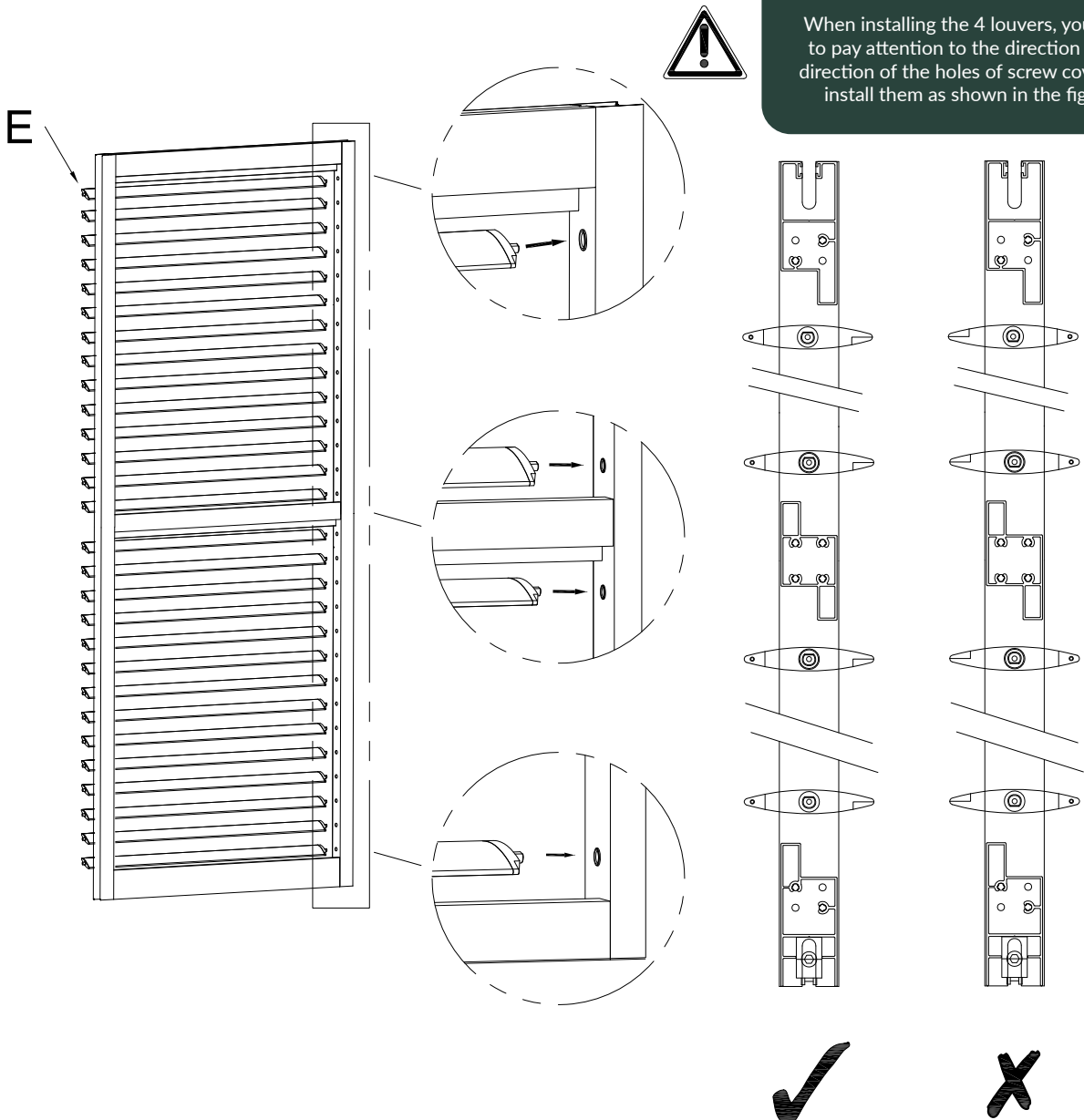

#### 4. Install louvers.

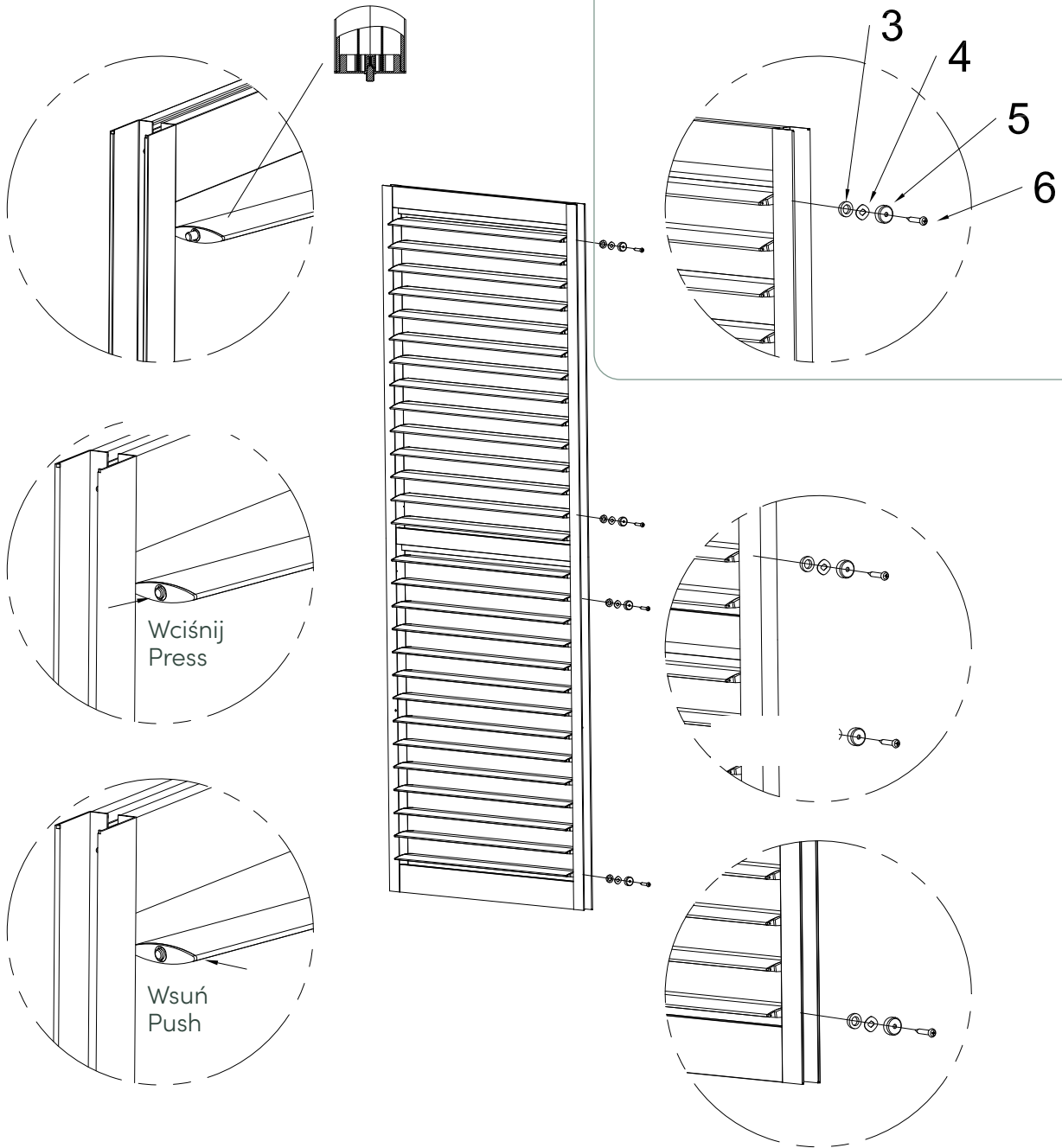

**UWAGA:** Podczas instalacji elementów tłumiących należy odpowiednio wyregulować dokręcenie śruby. Pozwoli to uniknąć sytuacji, w której żaluzje będą się zacinać lub obracać zbyt ciasno.

**NOTE:** When installing the damping device, the tightness of this screw needs to be adjusted during installation. So as avoid the situation that the louver does not rotate due to the increase of the damping.





3		x4	4		x4
5		x4	6	 ST4.2*10	x4

## 5. Montaż łącznika żaluzji.

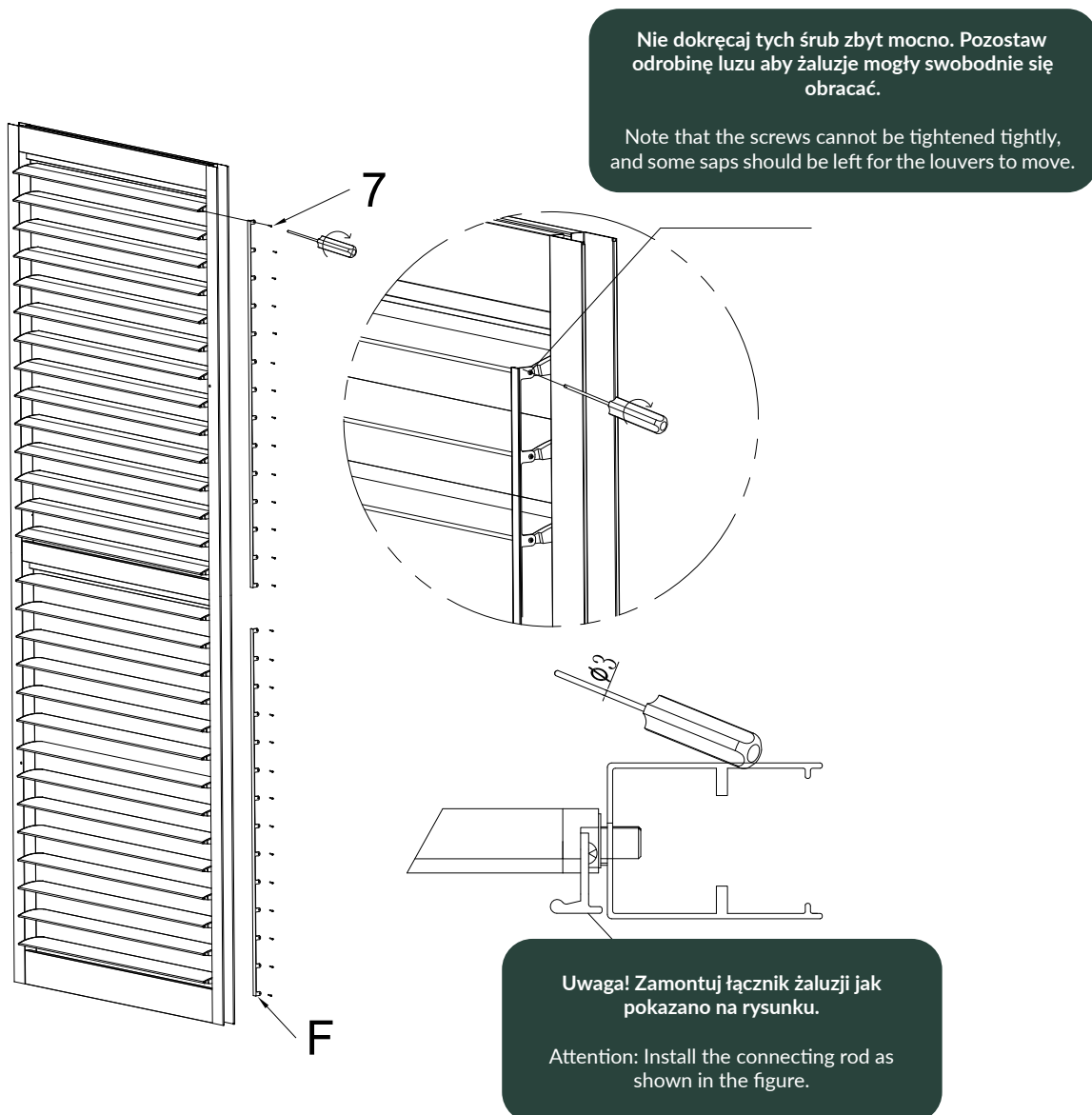
## 5. Install and active connecting rod.



<b>F</b> 		x2	<b>7</b>  x28 (218cm) x30 (238cm) ST2.2*14
--	---	----	--

## 6. Montaż osłon ramy.

## 6. Install cover plate.

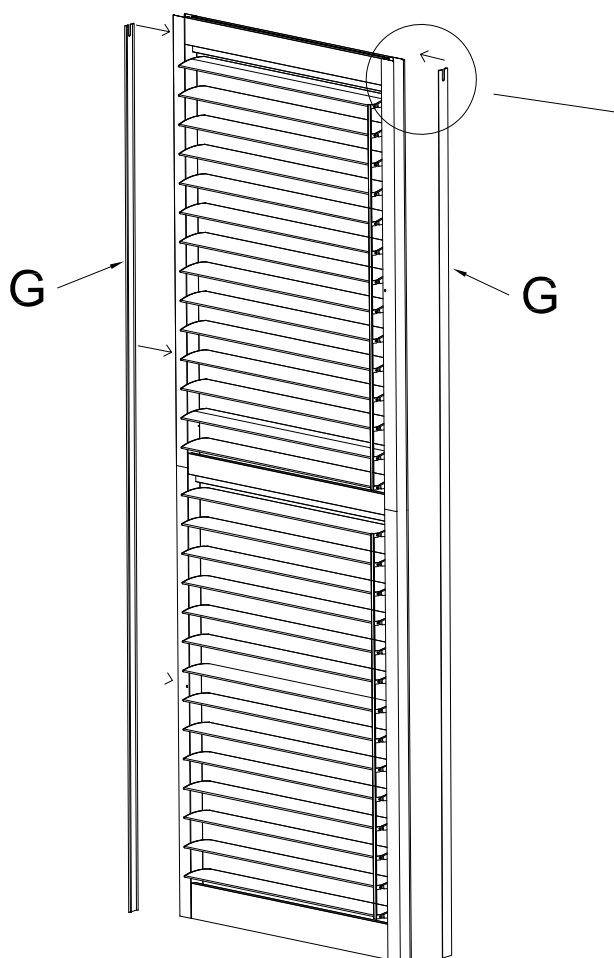

Aby ułatwić montaż osłony, wsuń najpierw jeden bok w rowek, a następnie wciśnij drugą stronę (możesz użyć gumowego młotka).



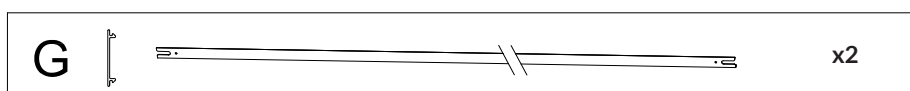
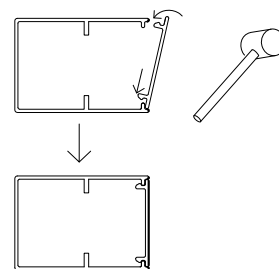



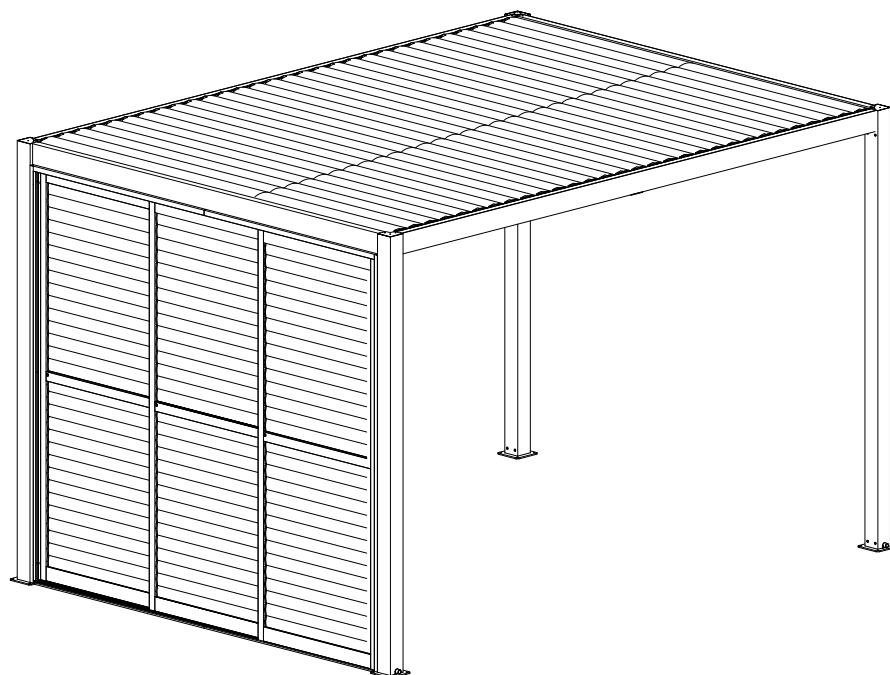

When installing, one end is snapped in first, and then rotated and knocked in.

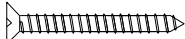

# Montaż paneli do pergoli (3M)

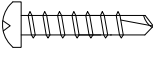
/ Mobile Dosor Installations for Installation (3m)

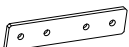
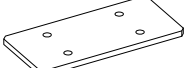

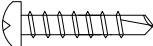
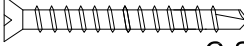

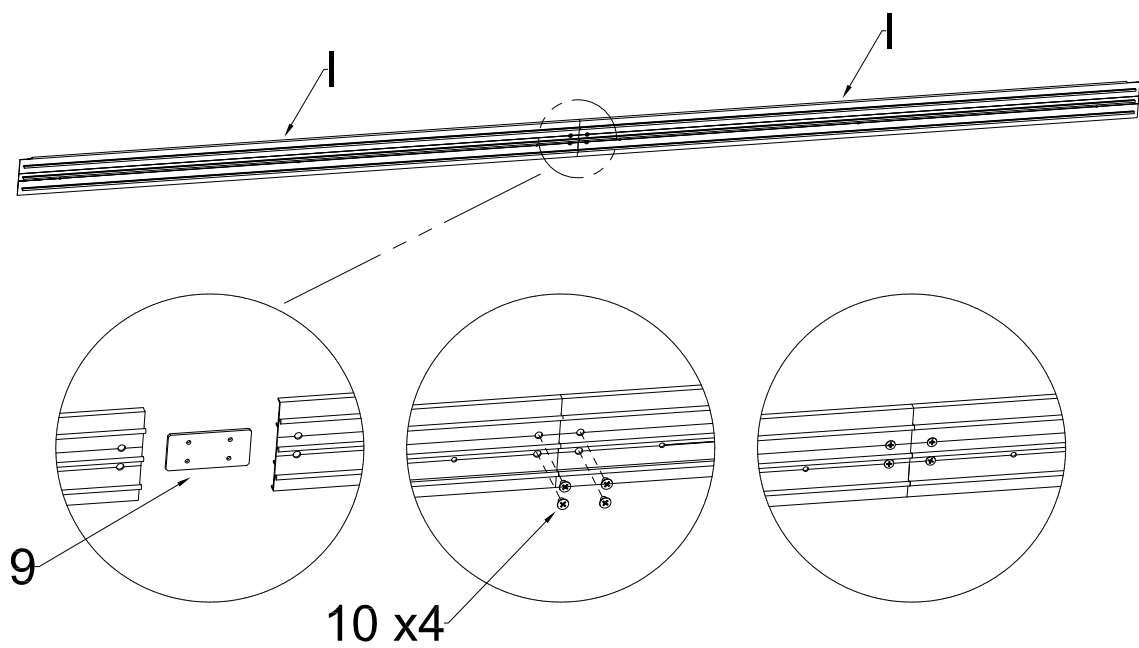
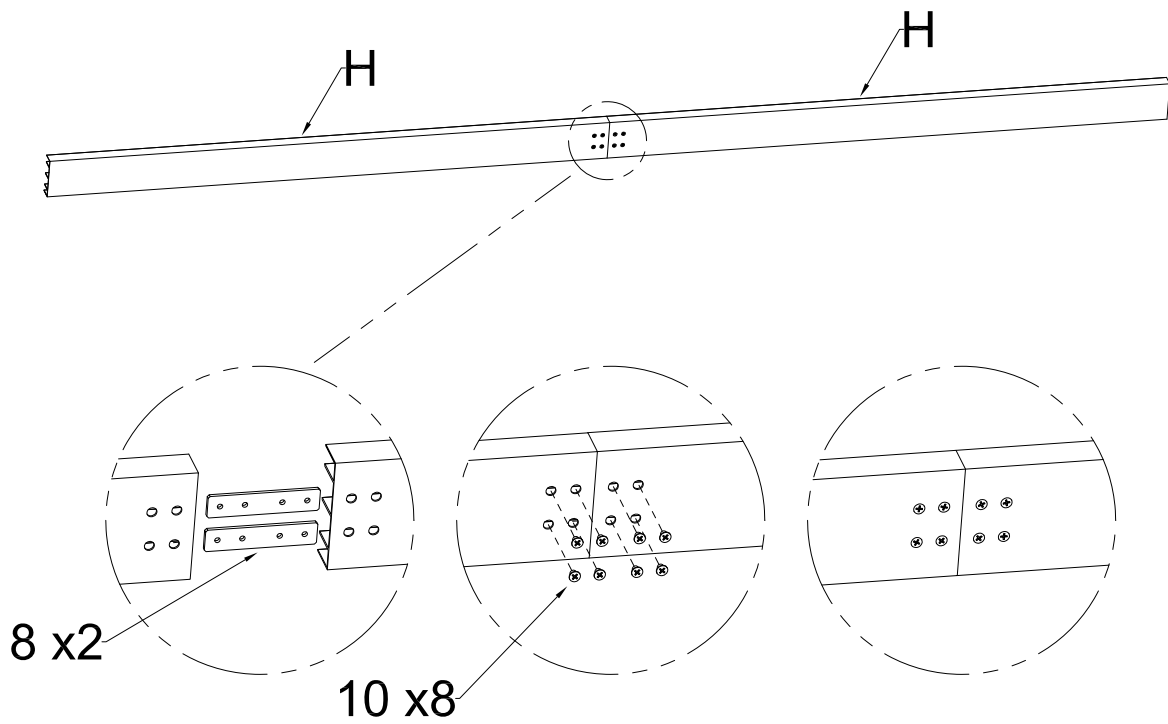

H	E		x2	VI	11		x6
							$\phi 6 \times 40$
I	J		x2	12		x6	
						$ST4.2 \times 40$	
J			x2	VII	13		x12
					14		x4
					15		x4
V	8		x2			$\phi 18 \times \phi 15 \times 5$	
	9		x1	VIII	16		x2
	10		x12		17		x4
			$M5 \times 6$			$C-ST4.2 \times 19$	
				IX	18		x2
						$C-ST4.2 \times 60$	

1. Łącznie górnej i dolnej szyny

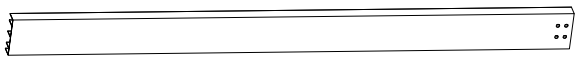
1. Splicing the upper and lower tracks together.

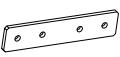
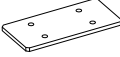

<b>H</b>		x2							
<b>I</b>		x2							
<b>8</b>		x2	<b>9</b>		x1	<b>10</b>		M5*6	x12

## 2. Montaż bocznej (lewej) szyny.

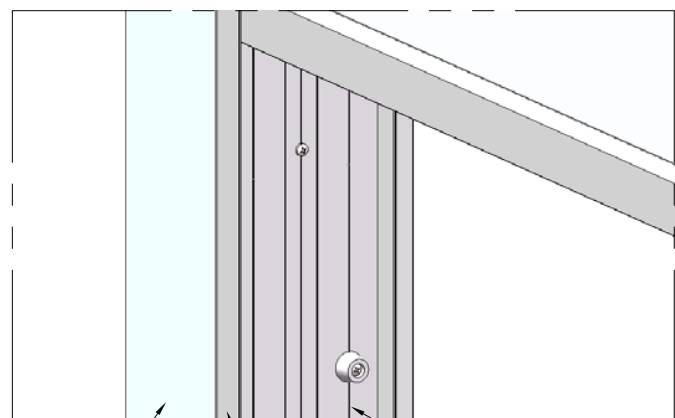
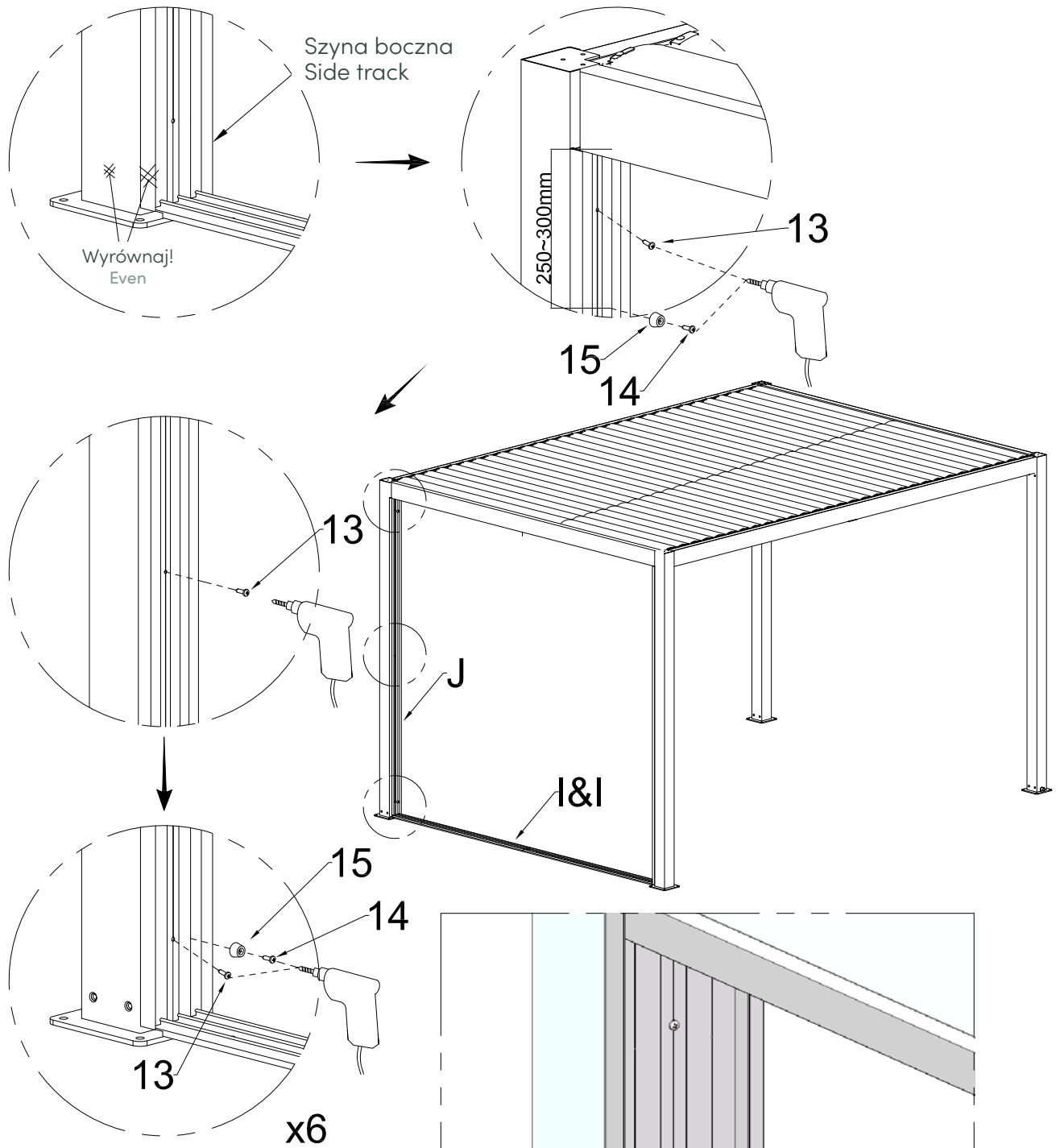

## 2. Fixed left side track.



Kolumna  
Column

Rowek  
Groove

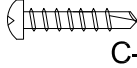
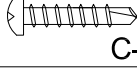

Szyrna boczna  
Side track

13		x3
14		x2
15		x2

### 3. Montaż bocznej (prawej) szyny.

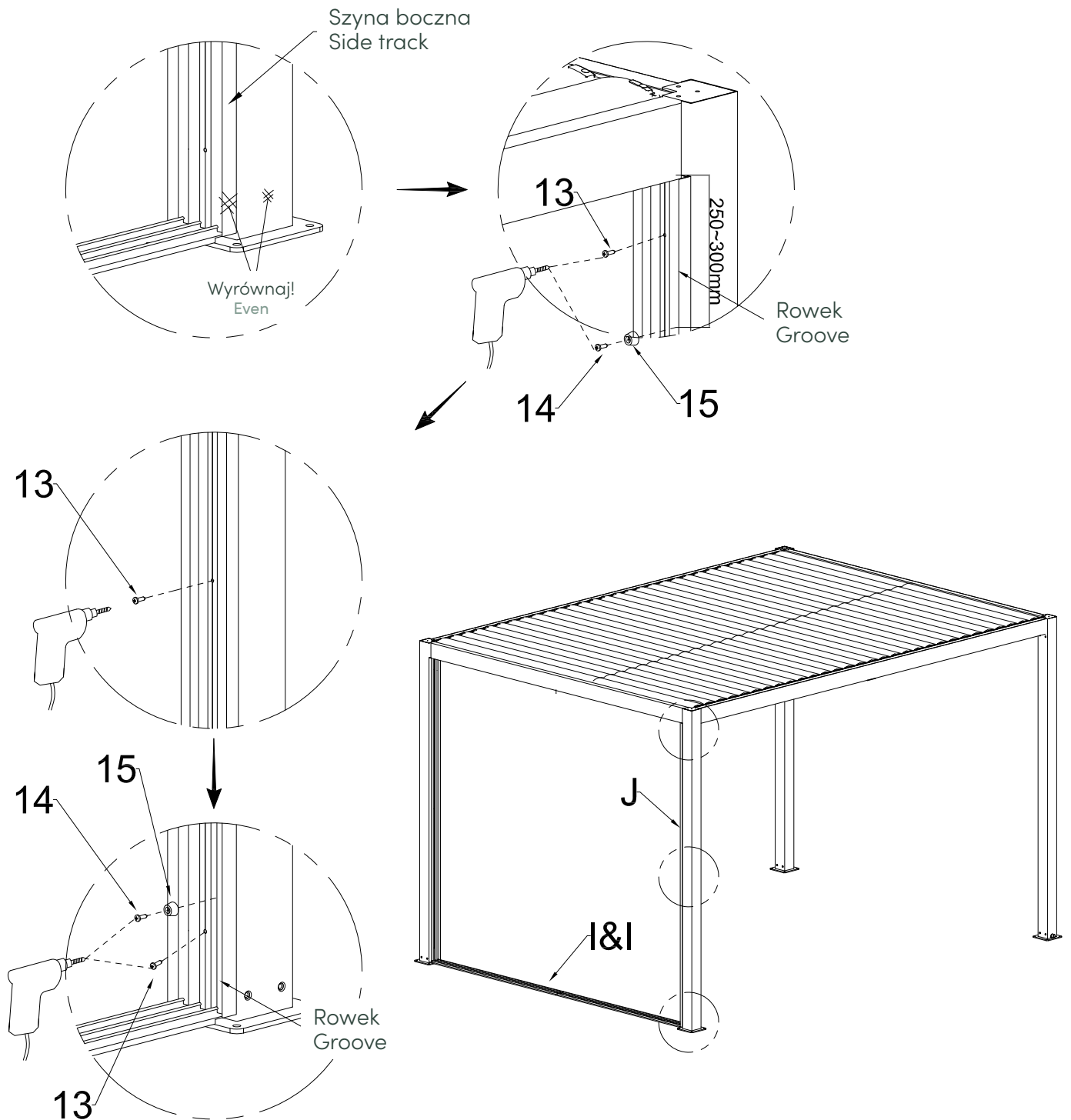
### 3. Fixed left side track.

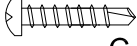
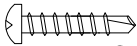

13		x3
	C-ST4.2*19	
14		x2
	C-ST3.5*19	
15		x2

#### 4. Montaż dolnej szyny.

#### 4. Fixed ground track.

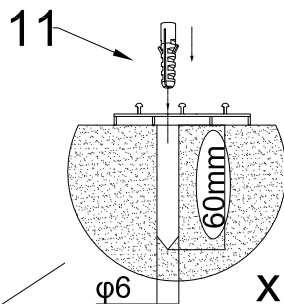
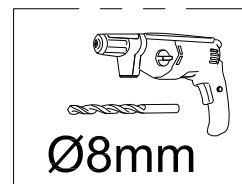
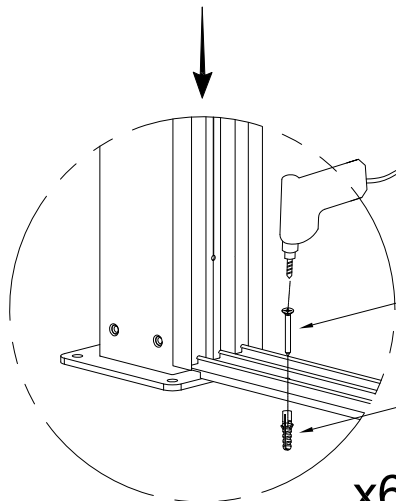
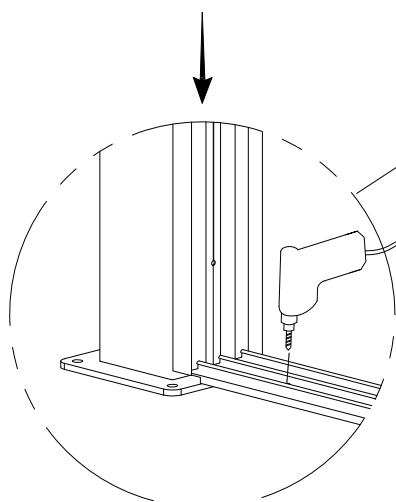
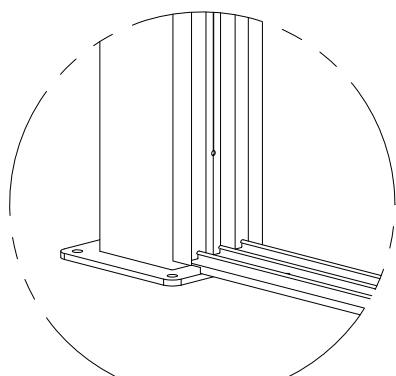

Umieść kołek rozporowy w wywierconym otworze.  
Knock the plastic expansion tube into the drilled hole.

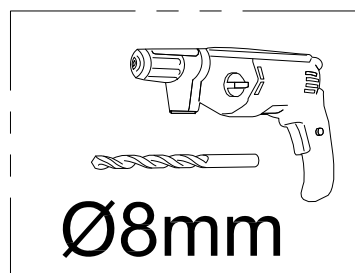
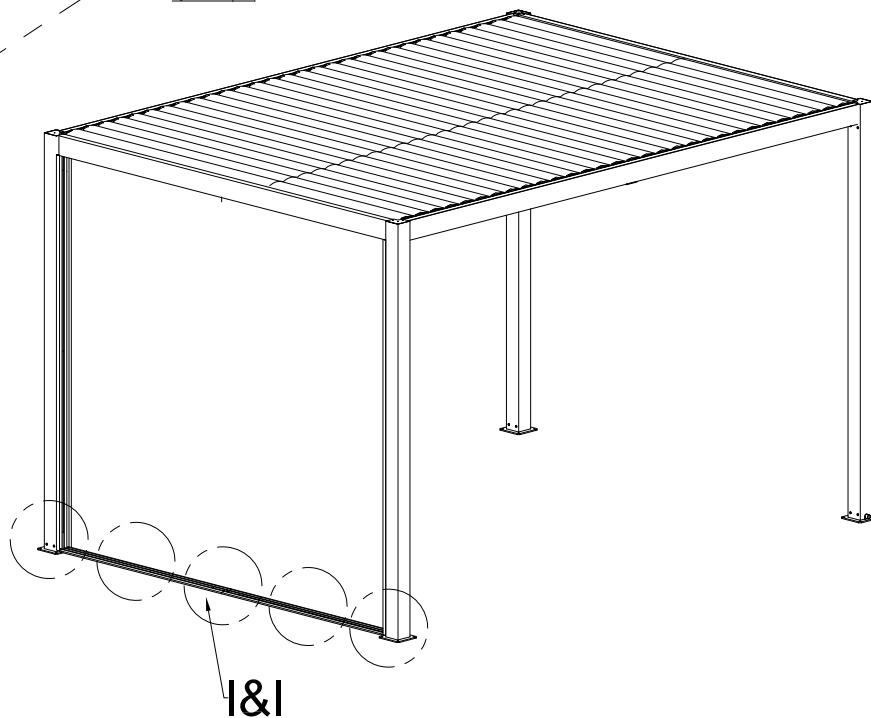

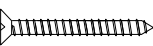
11		φ8*45	x6
12		ST5*60	x6

## 5. Montaż górnej szyny.

## 5. Fixed upper track.

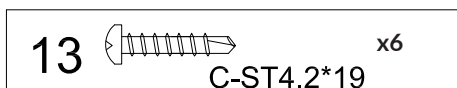
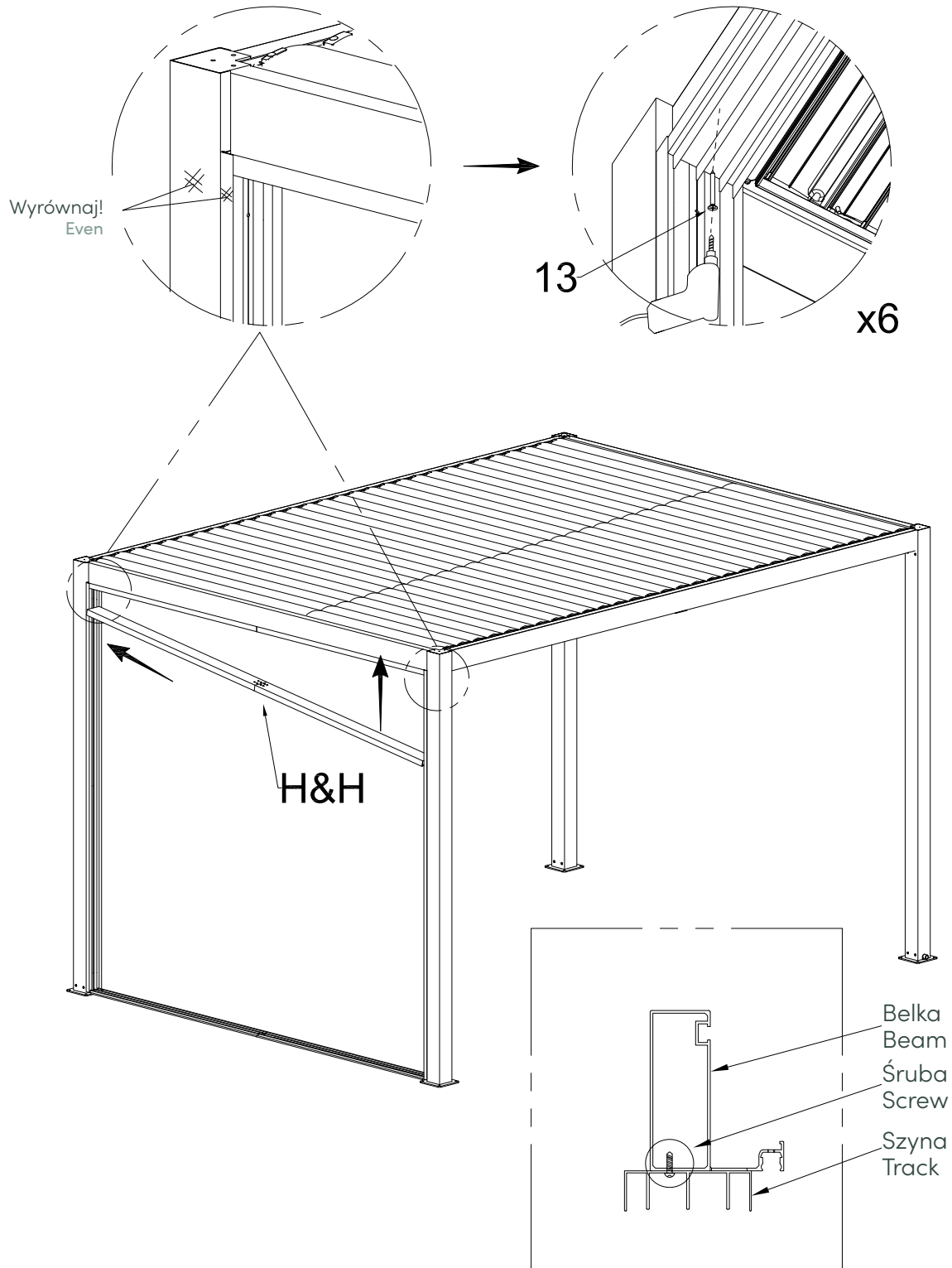

**UWAGA!** Zaleca się zamocowanie szyny w pozycji pokazanej na rysunku.

**ATTENTION.** It is recommended to fix the track in the position shown in the figure.

## 6. Montaż gotowych paneli żaluzyjnych.

## 6. Install three sets of doors and windows.

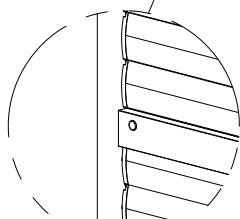
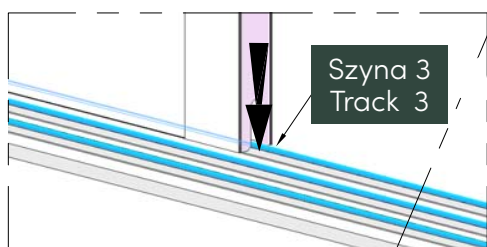
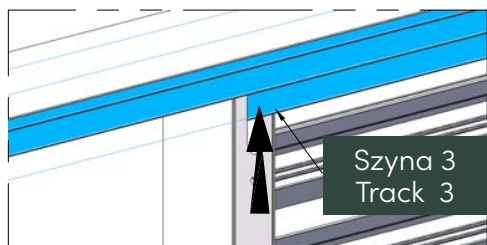

Pamiętaj, aby podczas montażu paneli, łącznik żaluzji był skierowany do wnętrza pergoli.

Please note that during the installation of the sliding door, the opening and closing push rod should face inward.

Zwróć uwagę, że ta część musi być skierowana w lewo.  
Please note that this area is facing left.

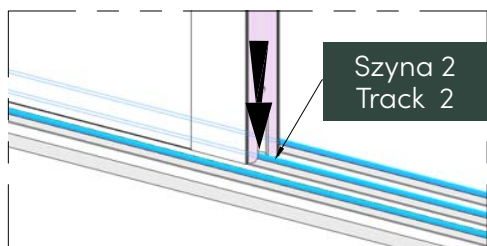
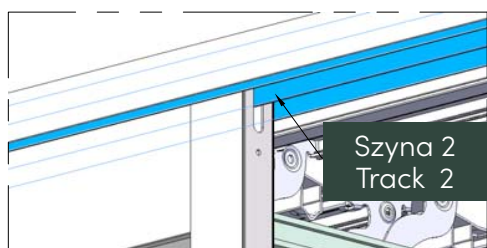

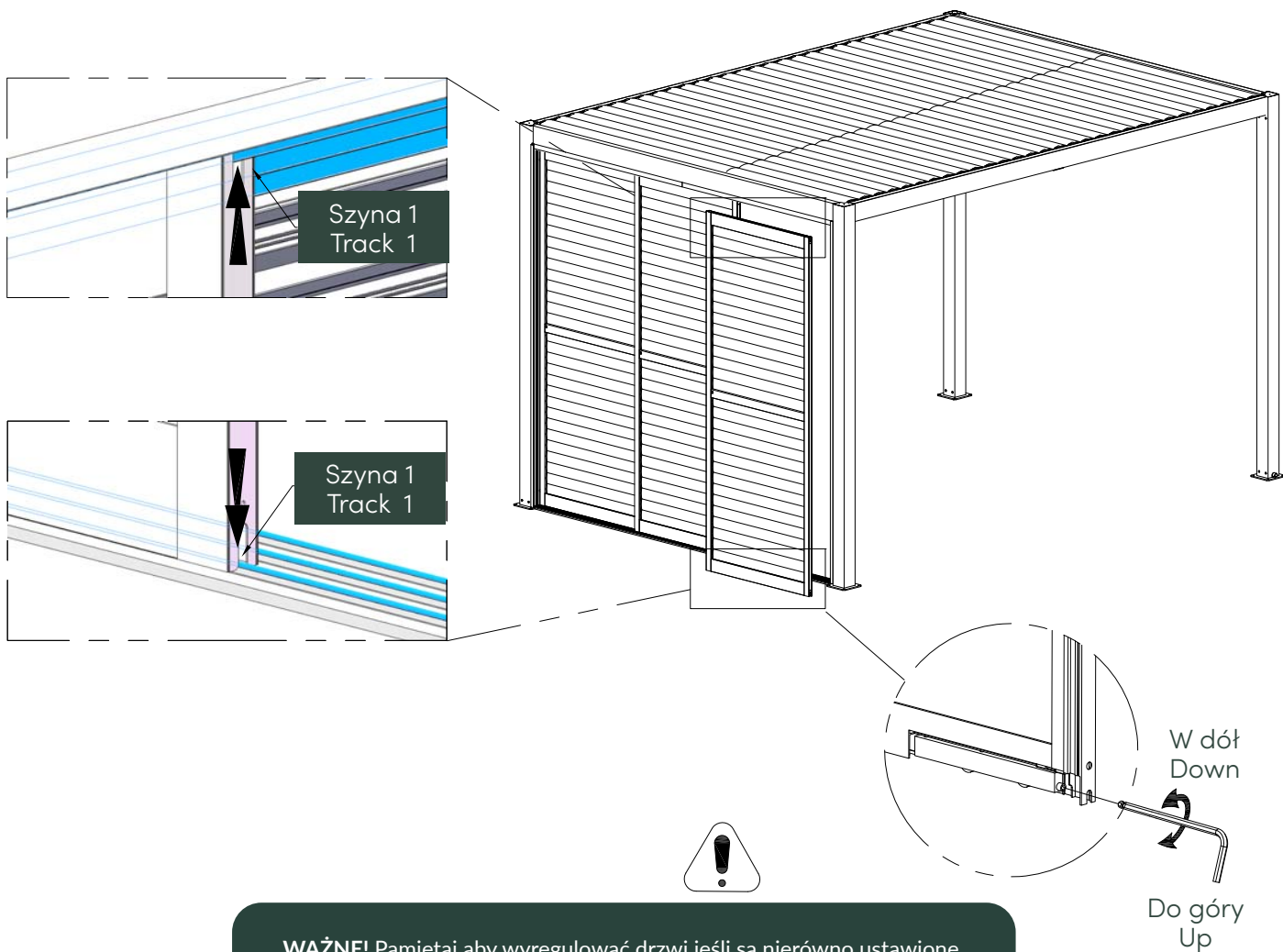

**WAŻNE!** Pamiętaj aby wyregulować drzwi jeśli są nierówno ustawione.  
 Note that if the sliding door is tilted, the pulley can be adjusted.

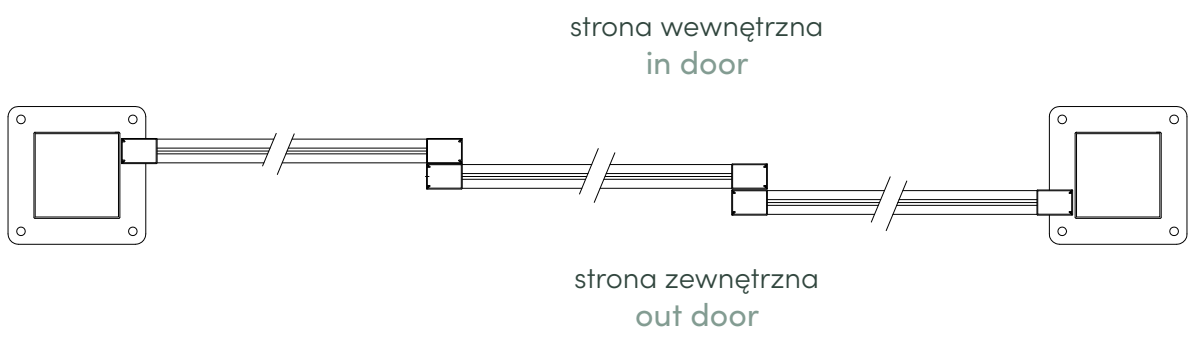

x2

x56 / x60

## 7. Montaż zamków.

## 7. Install the door lock.



**Uwaga: Unikaj wiercenia w bocznym słupku pionowym; wykonaj tylko otwór  $\text{\O}6,5$  mm w listwie uszczelniającej. Przed zamontowaniem zamka do drzwi należy w wyznaczonym miejscu zamontować stałą śrubę kotwiącą.**

**Note: Avoid drilling through the side vertical post; only drill a  $\text{\O}6.5$  hole on the sealing strip. Before installing the door lock, a fixed anchor screw must be installed at the designated position.**

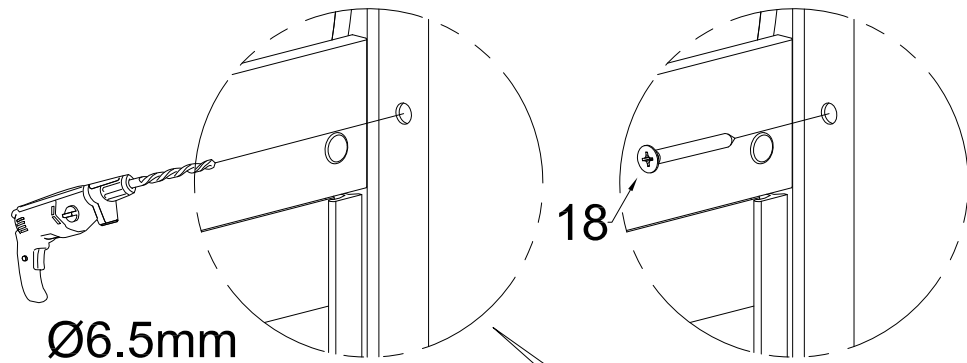

**Pozycja wiercenia musi być wyśrodkowana na panelu drzwiowym.**

**The drilling position must be centered on the door panel.**

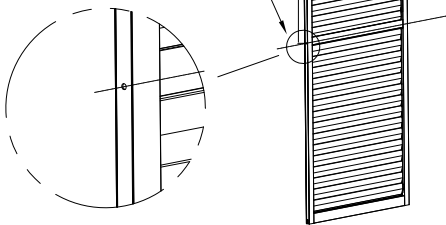

Zdemontuj  
Remove

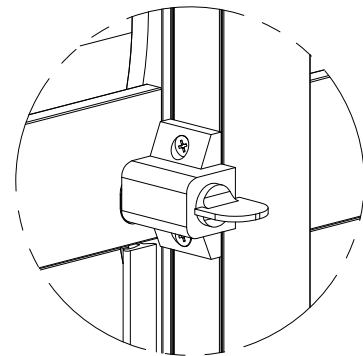
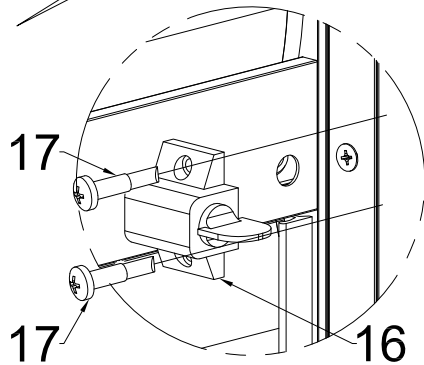
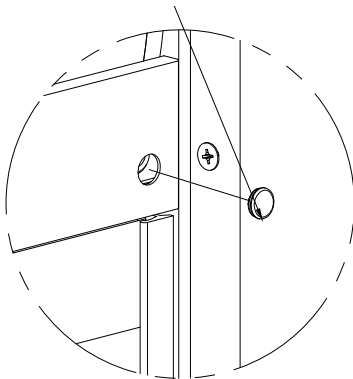







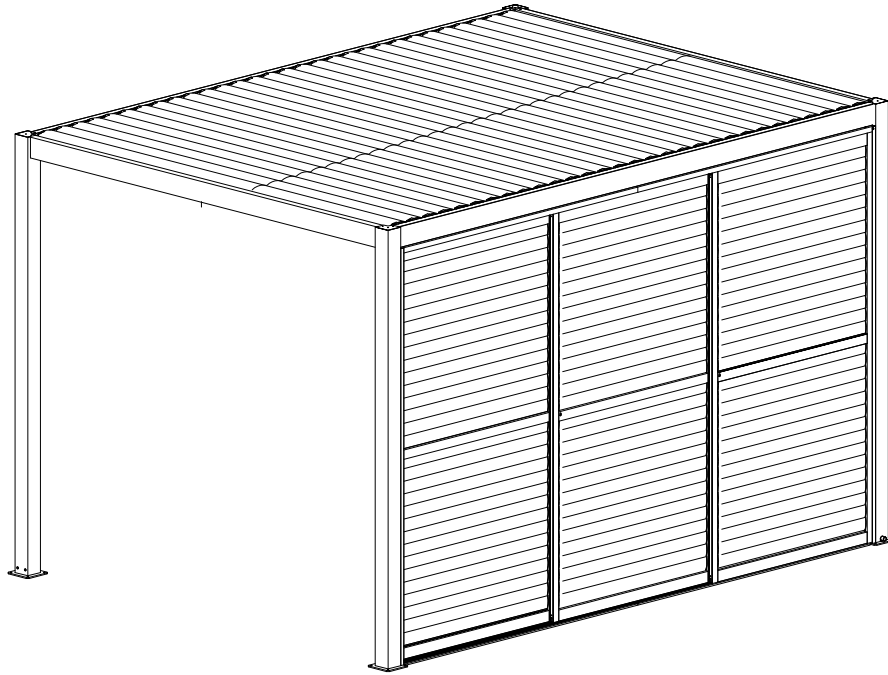



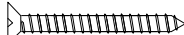

16		x2
17		x4
18		x2

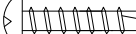
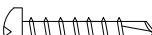
# Montaž paneli do pergoli (4M)

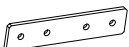
/ Mobile Dosor Installations for Installation (4m)

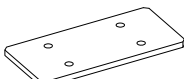

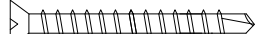

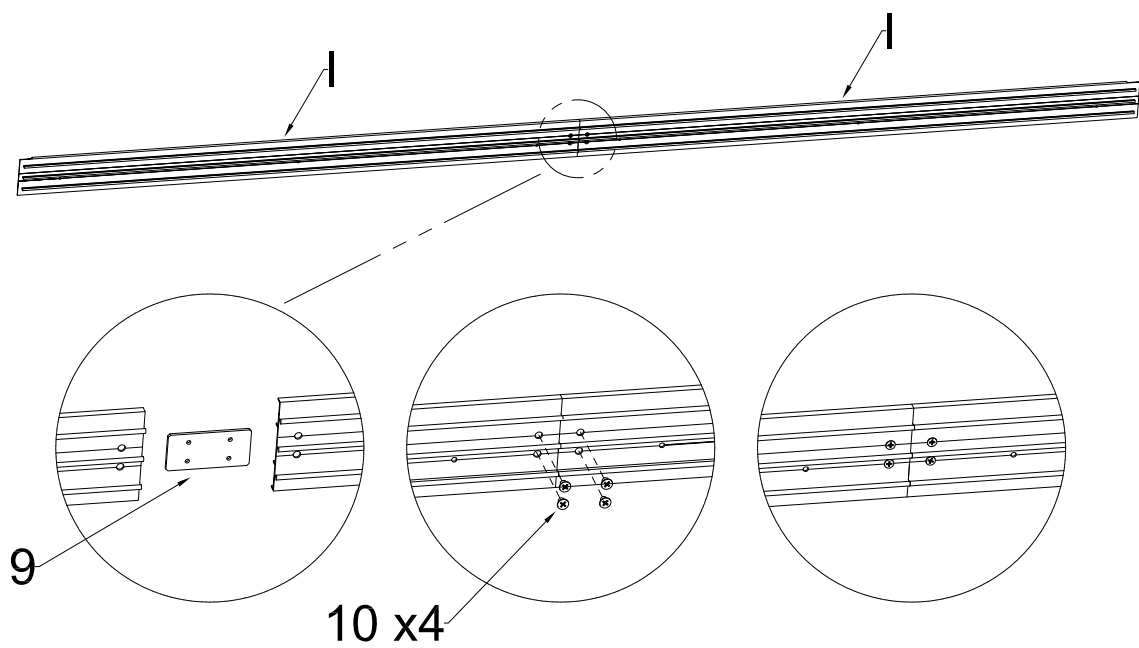
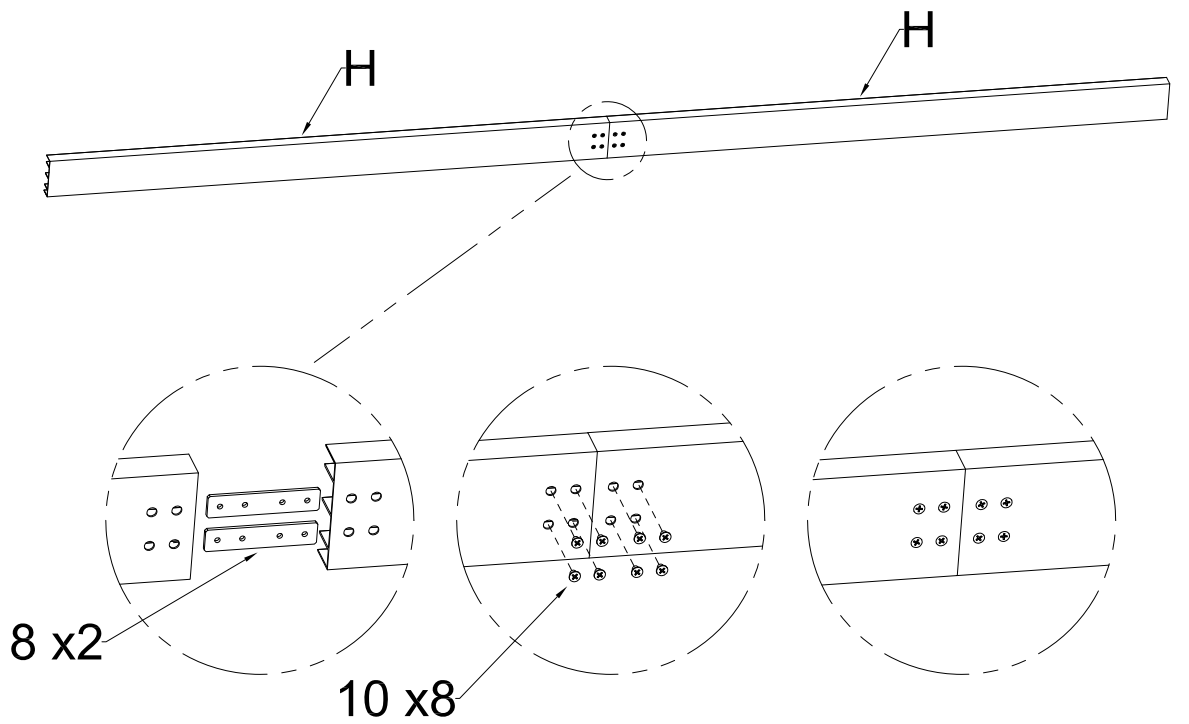

H			x2	VII	11		x6
	I				x2	12	
J			x2	VIII	13		x16
					14		x4
					15		x4
VI	8		x2	IX	16		x2
	9		x1		17		x4
	10		M5*6 x12		18		x2
						$\phi 6*40$	
						ST4.2*40	
						C-ST4.2*19	
						C-ST3.5*19	
						$\phi 18*\phi 15*5$	
						C-ST4.2*19	
						C-ST4.2*60	

1. Łącznie górnej i dolnej szyny

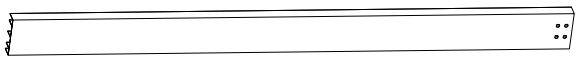
1. Splicing the upper and lower tracks together.

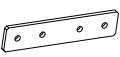
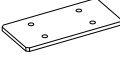



<b>H</b>		x2							
<b>I</b>		x2							
<b>8</b>		x2	<b>9</b>		x1	<b>10</b>		M5*6	x12

## 2. Montaż bocznej (lewej) szyny.

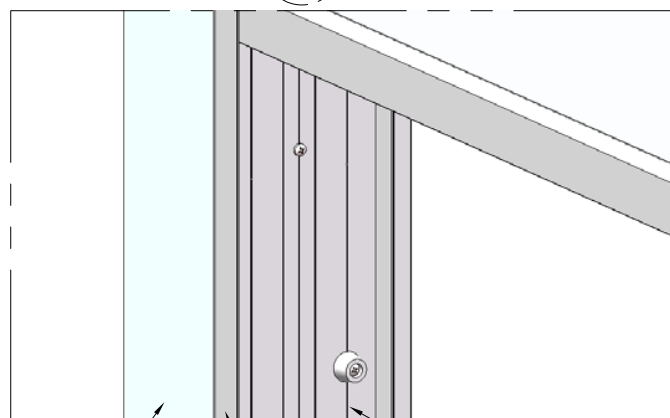
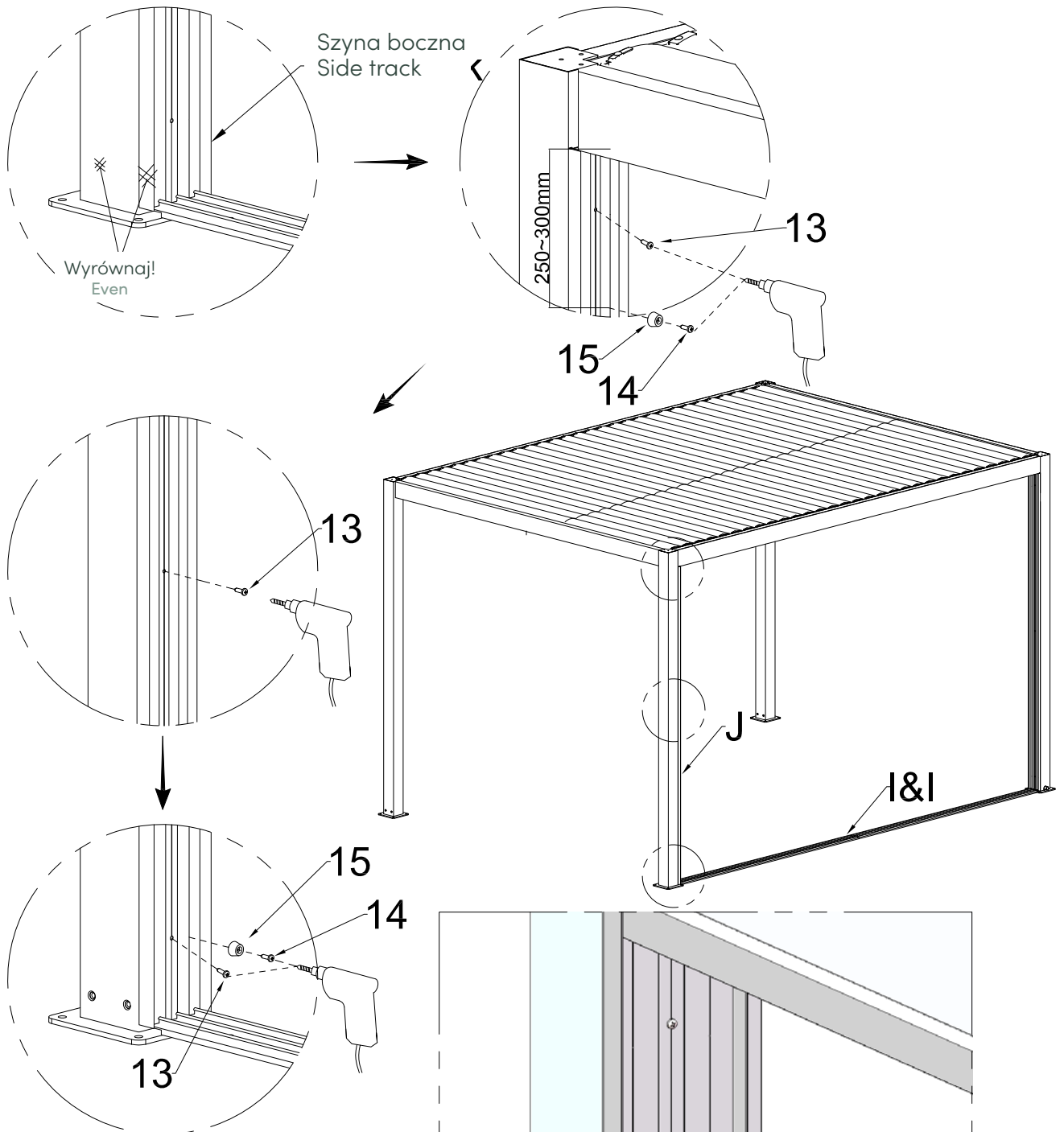
## 2. Fixed left side track.

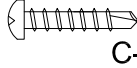
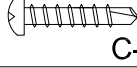



13		x3
	C-ST4.2*19	
14		x2
	C-ST3.5*19	
15		x2

### 3. Montaż bocznej (prawej) szyny.

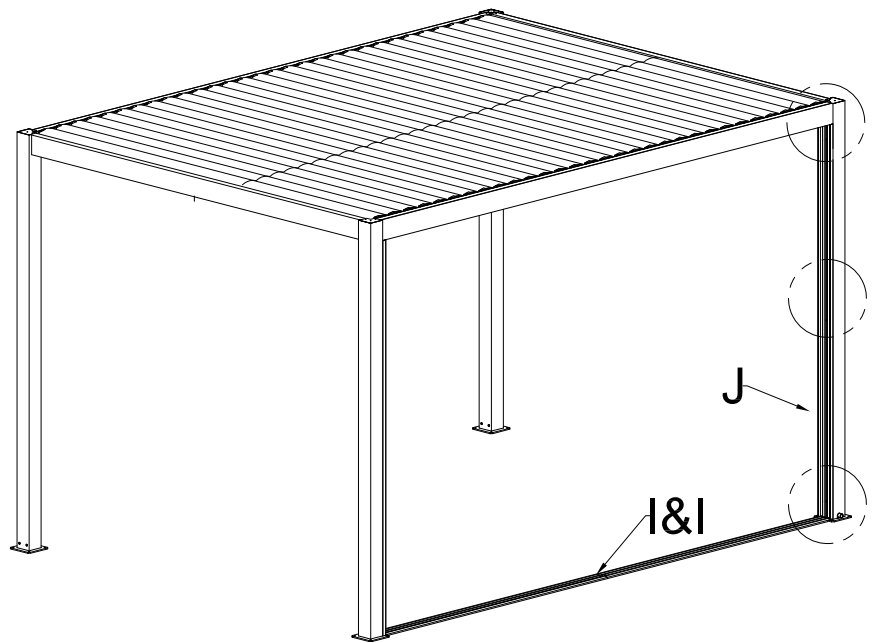
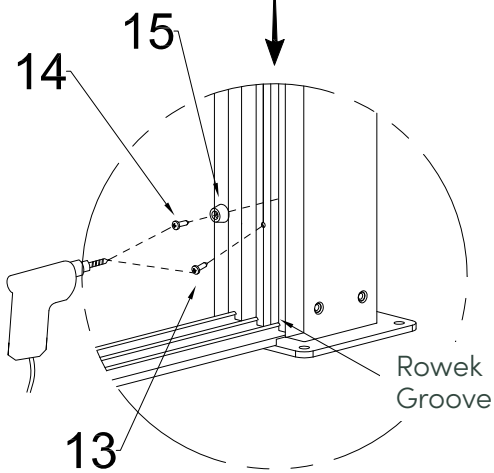
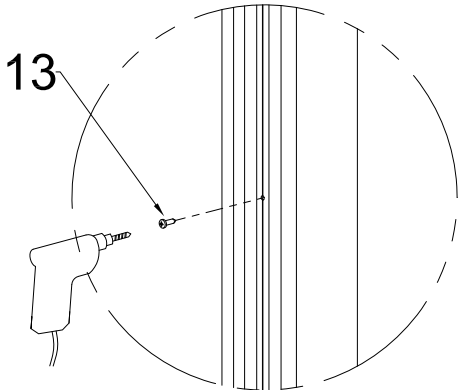
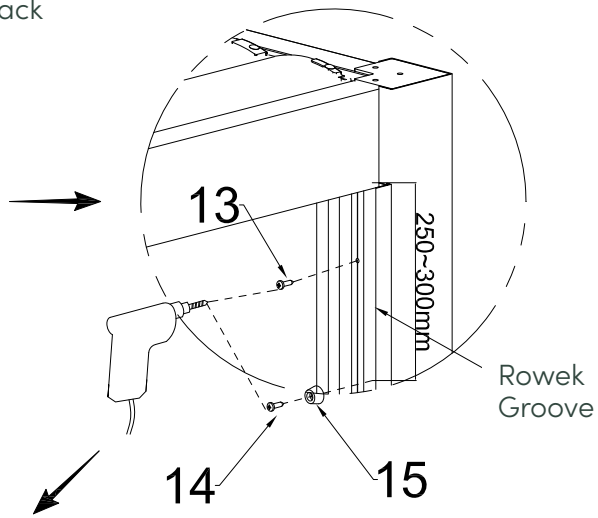
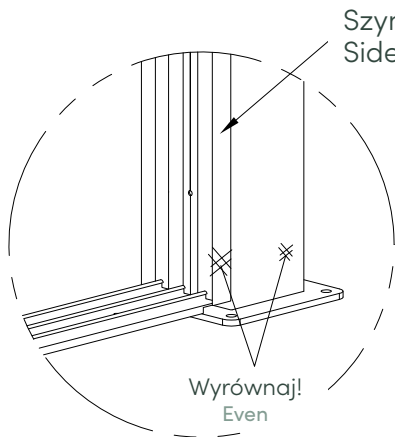
### 3. Fixed left side track.



13		x2
	C-ST4.2*19	
14		x2
	C-ST3.5*19	
15		x2

#### 4. Montaż dolnej szyny.

#### 4. Fixed ground track.

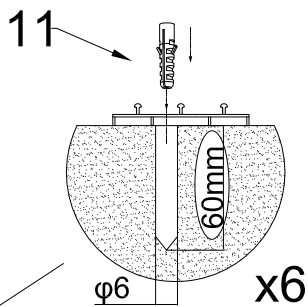
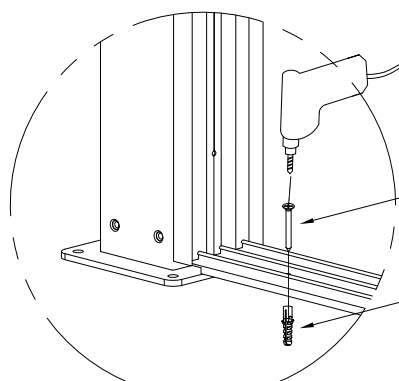
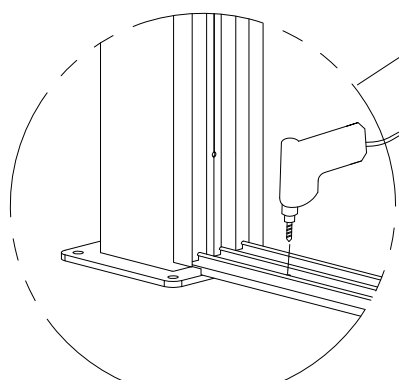
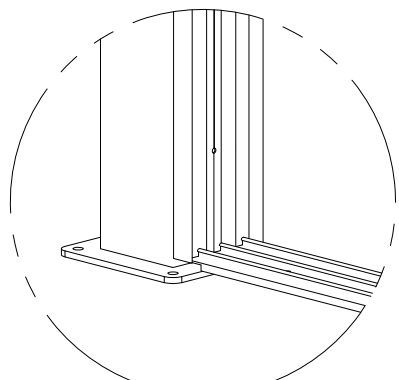

Umieść kołek rozporowy w wywierconym otworze.  
Knock the plastic expansion tube into the drilled hole.

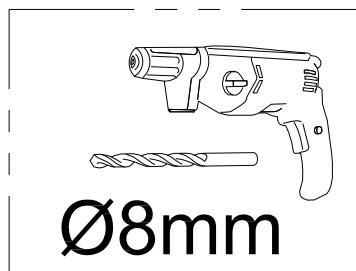
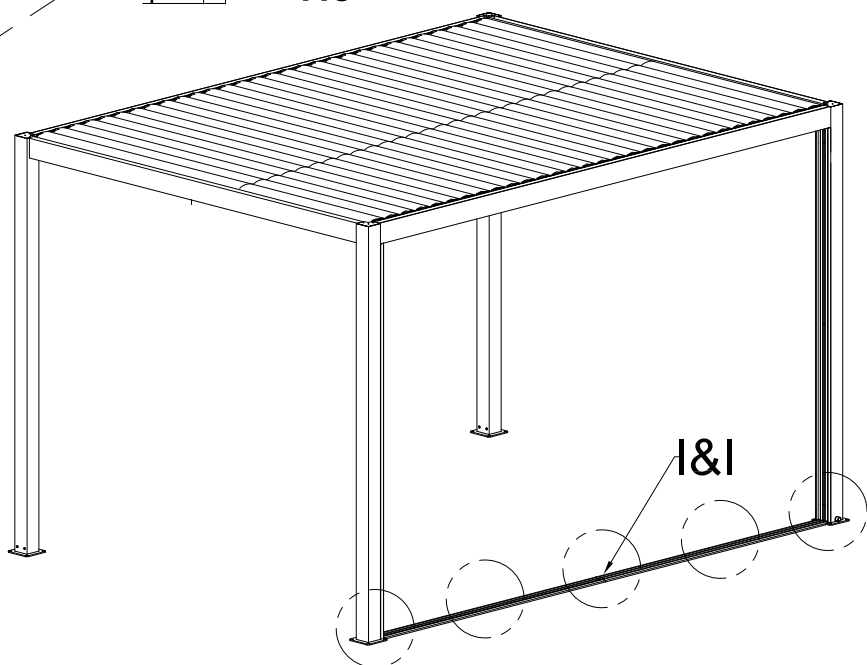

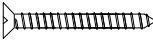
11		φ8*45	x6
12		ST5*60	x6

## 5. Montaż górnej szyny.

## 5. Fixed upper track.

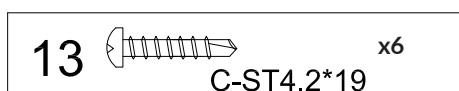
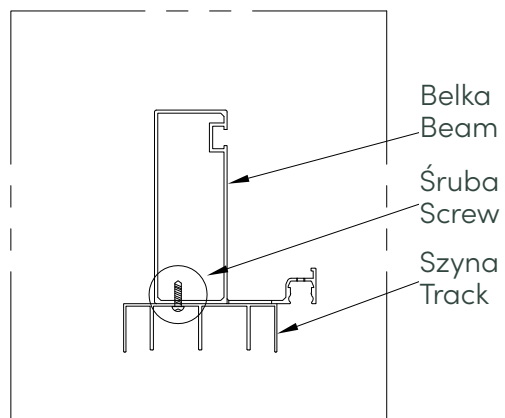
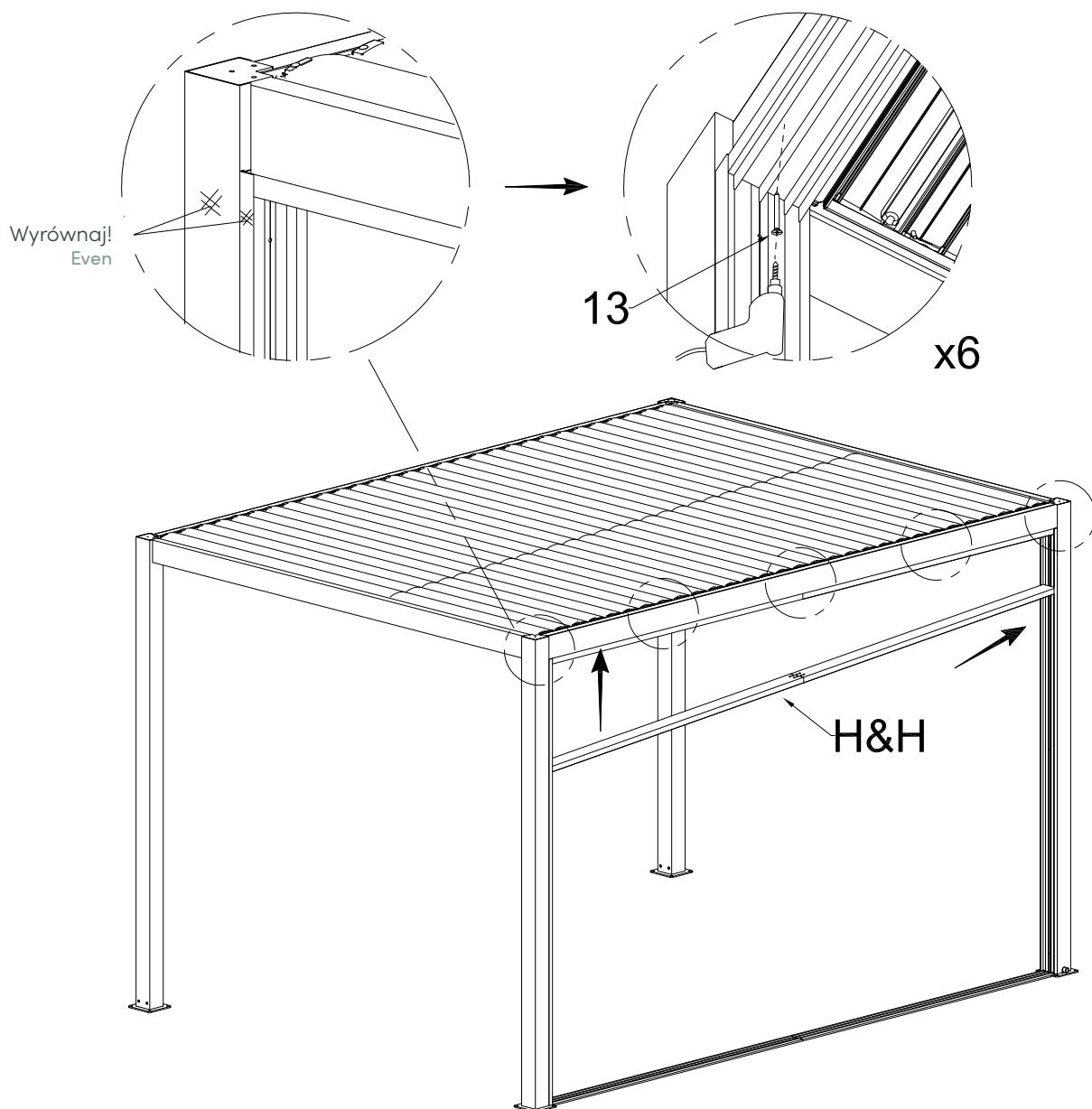

**UWAGA!** Zaleca się zamocowanie szyny w pozycji pokazanej na rysunku.

**ATTENTION.** It is recommended to fix the track in the position shown in the figure.

## 6. Montaż gotowych paneli żaluzyjnych.

## 6. Install three sets of doors and windows.

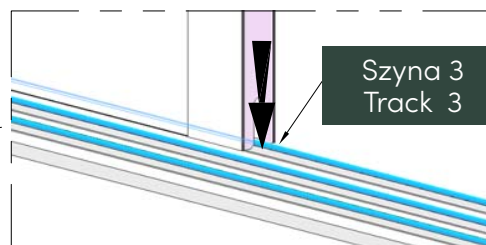
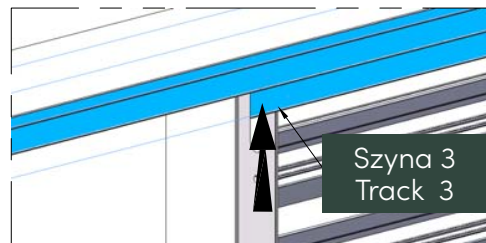
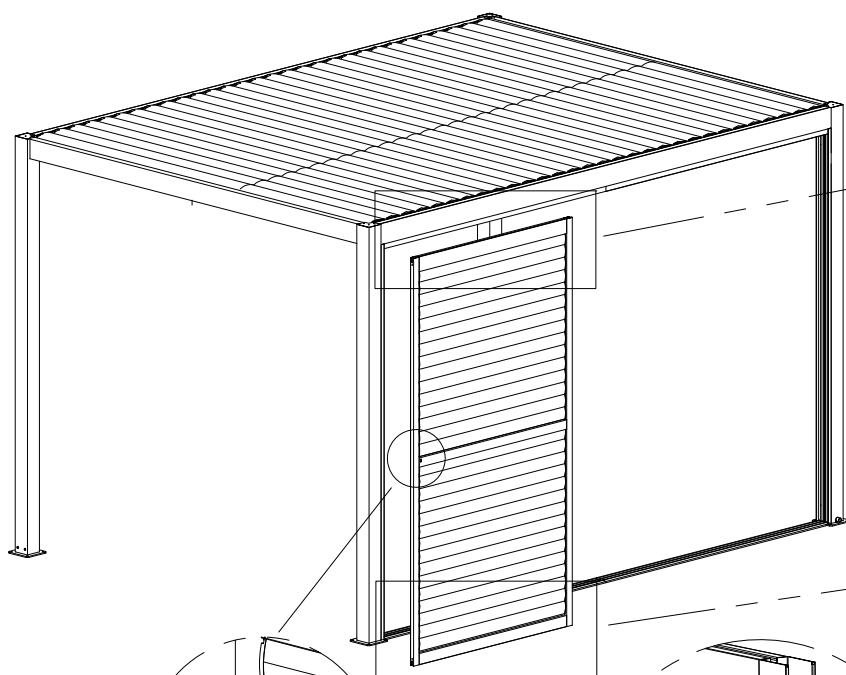

Zwróć uwagę, że ta część musi być skierowana w lewo.  
Please note that this area is facing left.

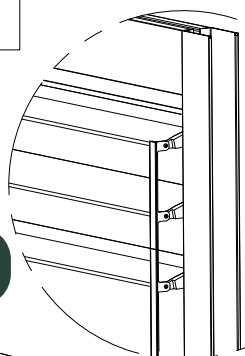

Pamiętaj, aby podczas montażu paneli, łącznik żaluzji był skierowany do wnętrza pergoli.

Please note that during the installation of the sliding door, the opening and closing push rod should face inward.

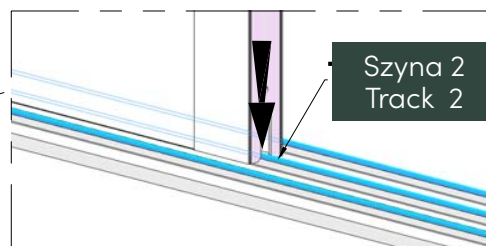
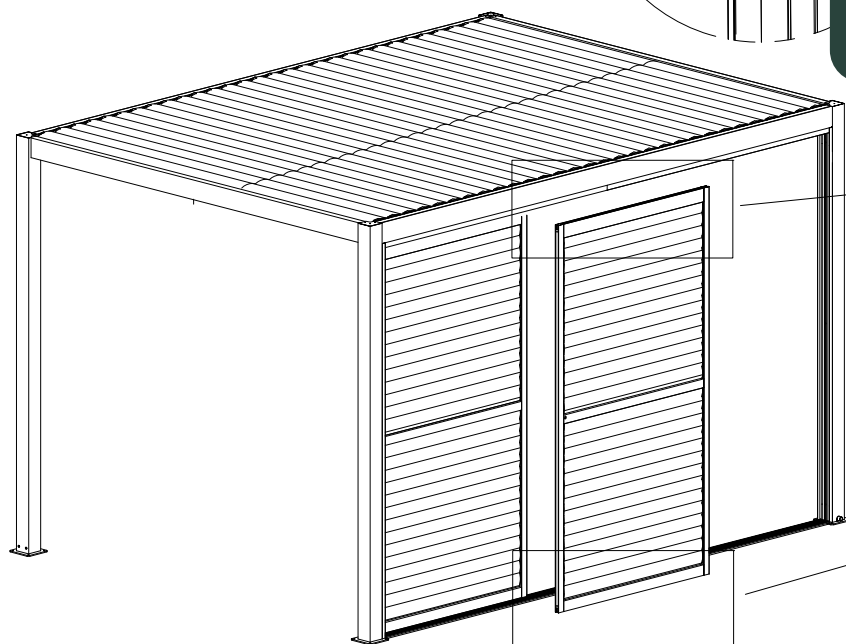

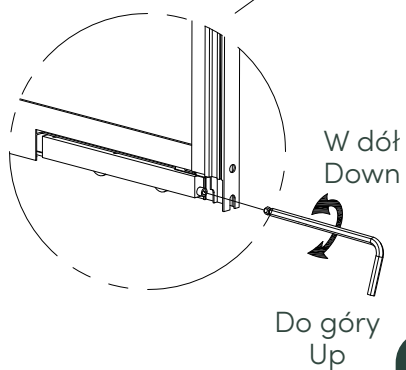
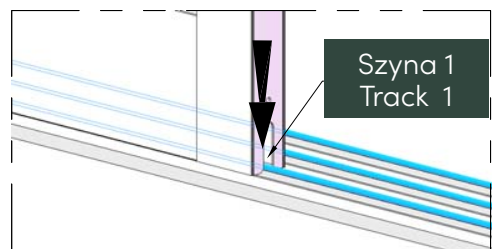
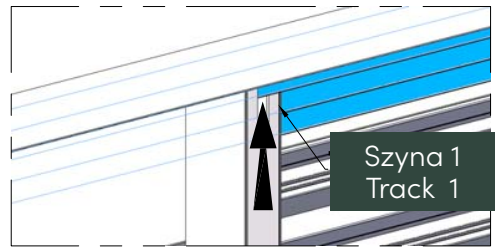
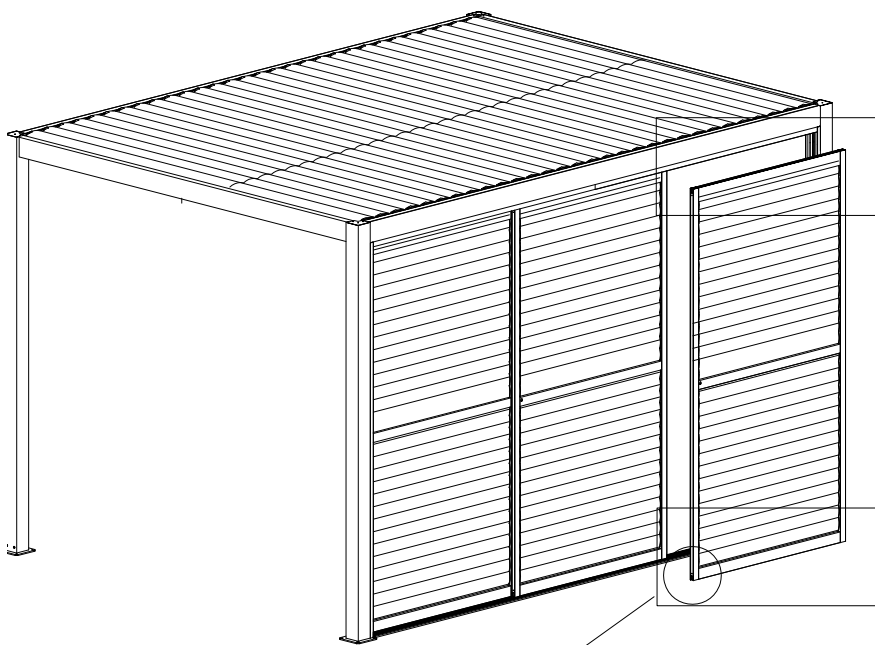

**WAŻNE!** Pamiętaj aby wyregulować drzwi jeśli są nierówno ustawione.  
 Note that if the sliding door is tilted, the pulley can be adjusted.

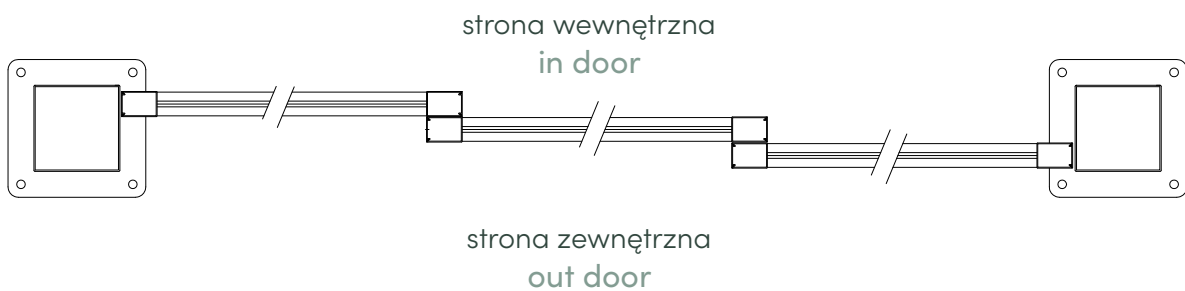

## 7. Montaż zamków.

## 7. Install the door lock.



**Uwaga:** Unikaj wiercenia w bocznym słupku pionowym; wykonaj tylko otwór  $\text{Ø}6,5$  mm w listwie uszczelniającej. Przed zamontowaniem zamka do drzwi należy w wyznaczonym miejscu zamontować stałą śrubę kotwiącą.

**Note:** Avoid drilling through the side vertical post; only drill a  $\text{Ø}6.5$  hole on the sealing strip. Before installing the door lock, a fixed anchor screw must be installed at the designated position.

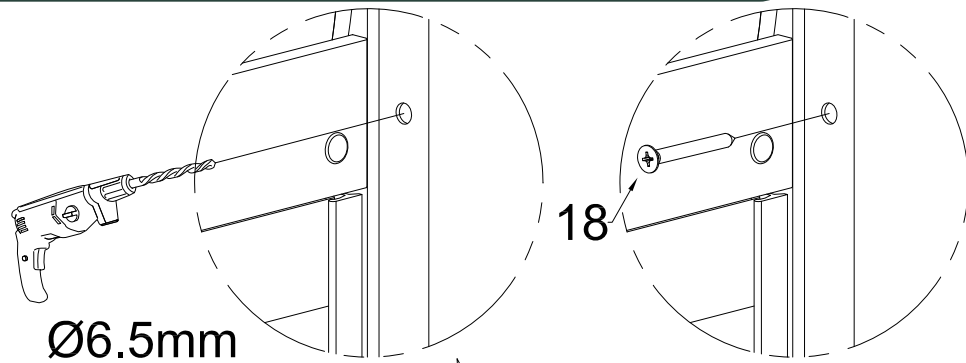

**Pozycja wiercenia musi być wyśrodkowana na panelu drzwiowym.**

The drilling position must be centered on the door panel.

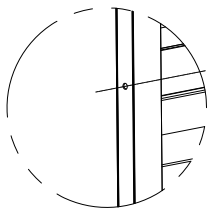

1/2H

Zdemontuj  
Remove

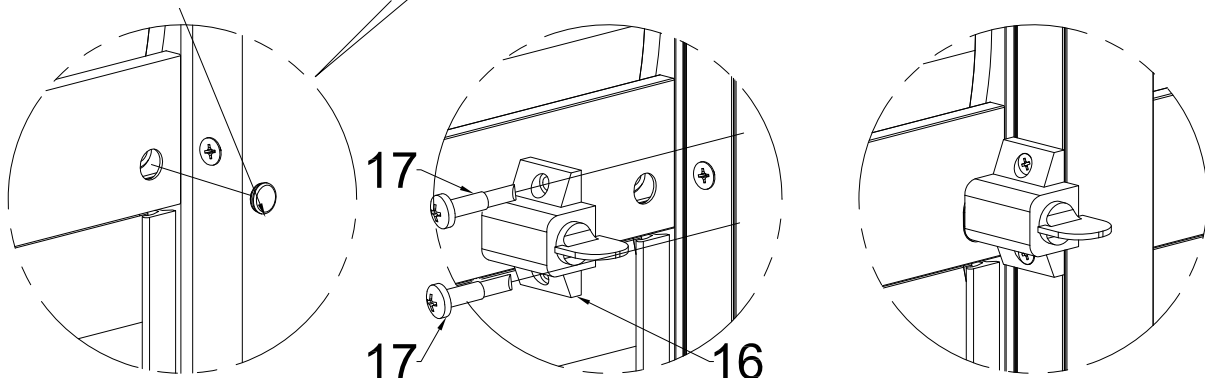

16		x2	
17		x4	C-ST4.2*19
18		x2	C-ST4.2*60

**Producent:**

Mirpol sp. z o.o.  
ul. Ciasna 3, 35-232 Rzeszów

[biuro@mirpol.rzeszow.pl](mailto:biuro@mirpol.rzeszow.pl)  
[www.mirpol.rzeszow.pl](http://www.mirpol.rzeszow.pl)

Made in China

**esti&esta<sup>®</sup>**